

## Selective Harmonics Elimination Technique in Cascaded H-Bridge Multi-Level Inverters Using the Salp Swarm Optimization Algorithm

M. Hosseinpour<sup>\*</sup>, S. Mansoori, H. Shayeghi

Department of Electrical and Computer Engineering, University of Mohaghegh Ardabili, Ardabil, Iran.

**Abstract-** A new optimization method is proposed in this paper for finding the firing angles in multi-level voltage source inverters to eliminate low-order selective harmonics and reduce total harmonic distortion (THD) value of the output voltage. For this end, Fourier series is used for calculating objective function and selecting specific harmonics. Regarding the nature and complexity of the employed non-algebraic equations in the optimization problem for achieving the optimal angle in the multi-level inverter, a recent developed meta-heuristic method known as Salp Swarm Algorithm (SSA) is presented. In the proposed method, the optimal angles for a given multi-level inverter are obtained based on the objective function such that the magnitudes of the selective harmonics and the THD value of the output voltage are reduced. The method is applied on a cascaded H-bridge type five-level inverter. The simulation results illustrate that the magnitudes of the selective harmonics and the THD percentage of the output voltage have been reduced through selecting the optimal switching angle by the proposed optimization algorithm. The result of this method are compared with those of SPWM method. Moreover, the performance of SSA algorithm with respect to PSO algorithm is compared which shows its rapid convergence speed and less THD value.

**Keyword:** Cascaded multi-level H-bridge inverter, Salp swarm optimization algorithm, Selective harmonics elimination, Total harmonic distortion (THD).

### 1. INTRODUCTION

Multi-level inverters (MLIs), as a voltage source, can generate a desired output using different levels of input DC voltages. By utilizing sufficient number of different DC sources in the input side, a sinusoidal-like voltage waveform can be produced. MLIs have greatly been taken into account for high voltage and power applications during the last years [1–5]. Because of the advantages of MLIs, including smaller input voltage, small voltage stress on semi-conductor power switches, reduced THD values, and closeness of the output voltage to a sinusoidal waveform, they are mainly used in medium and high power applications [6]. Some low-order harmonics are reduced through using MLIs and this leads to power quality improvement. Today, MLIs are mostly employed for energy transformation in renewable energy section such as solar or wind energies due to the existence of variable inputs with small amplitudes [7]. MLIs maintain different structures, including clamped

diode [8], flying capacitor [9], and cascaded H-bridge MLI (CHB-MLI) [10]. Among these various structures, the last one, i.e., CHB-MLI has received more attention due to its low number of consisting elements and simple control scheme [10]. In modern power systems, power is conducted through high-power inverters. According to the increased electrical power demands, putting limitations on switching loss in a tolerable range in such high-power inverters will reduce the overall power loss and increase the efficiency [11,12]. Therefore, it is an essential to select a suitable modulation method for reducing harmonic distortions in the output.

Many various methods have been suggested regarding different techniques used for MLI switching with low frequency switching structure. To control the output voltage and reduce unintended harmonics, pulse width modulation (PWM) techniques are usually considered in MLIs [13]. PWM techniques are widely classified as follows: sinusoidal PWM (SPWM), space vector modulation (SVM), and selective harmonics elimination (SHE) [14]. SHE method is used for eliminating low-order harmonics by expanding Fourier series to sinusoidal wave and calculating harmonics components with the help of a set of nonlinear and non-algebraic equations. These non-algebraic equations are calculated in a specific manner, and the angles of Fourier series

Received: 09 Dec. 2018

Revised: 04 Apr. 2019

Accepted: 27 Apr. 2019

\*Corresponding author: Majid Hosseinpour

E-mail: [hoseinpour.majid@uma.ac.ir](mailto:hoseinpour.majid@uma.ac.ir)

Digital object identifier: 10.22098/joape.2019.5545.1418

**Research Paper**

© 2020 University of Mohaghegh Ardabili. All rights reserved.

expansion relationships are determined such that low-order harmonics become equal to zero and meanwhile the fundamnetal component remains in the default value [15,16].

Many different methods have been proposed for solving non-algebraic and nonlinear equations. SHE technique is divided into three main groups: 1) numerical methods (NMs), 2) algebraic methods (AMs), and 3) bio-inspired intelligent algorithms (BIAs) [17]. A summary of these methods is given in Fig. 1. Advantages and disadvantages of each group are explained in the following paragraphs. NMs are rapid iteration methods and calculate the optimal solutions in a few number of iterations. Due to accurate calucation capability, these methods are mainly employed [18]. Nonetheless, they heavily depend on the initial guess and if it lacks a suitable initial guess then it will reach local minimum. Some of NMs are Walsh function [19], sequential quadratic programming [20], homotopy algorithm [21], gradient optimization [22], and Newton-Raphson [23].

In AM method, non-algebraic nonlinear equations are transformed to polynomial equation to find the optimal angles. The main advantage of this technique is finding all solutions without using any initial guess [18]. Some of AM methods include Resultant theory [24], Groebner Bases theory [25], symmetric polynomial theory [26], Wu method [27], and power sum method [28], that are used for eliminating selective harmonics in inverters. These methods are computationally complex and are only applicable for low-level inverters. Hence, they are not employable for real-world applications of inverters.

BIA method is a type of intelligent nature inspired methods. Such methods are based on iteration and determine the optimal solution according to the initial population. Among the advantages of these methods one can name: no requirement to an initial guess, easy implementation, rapid and accurate solution, low complexity, applying different objective functions, and easy implementation of linear and nonlinear equations. To solve the SHE problem using BIA method, different

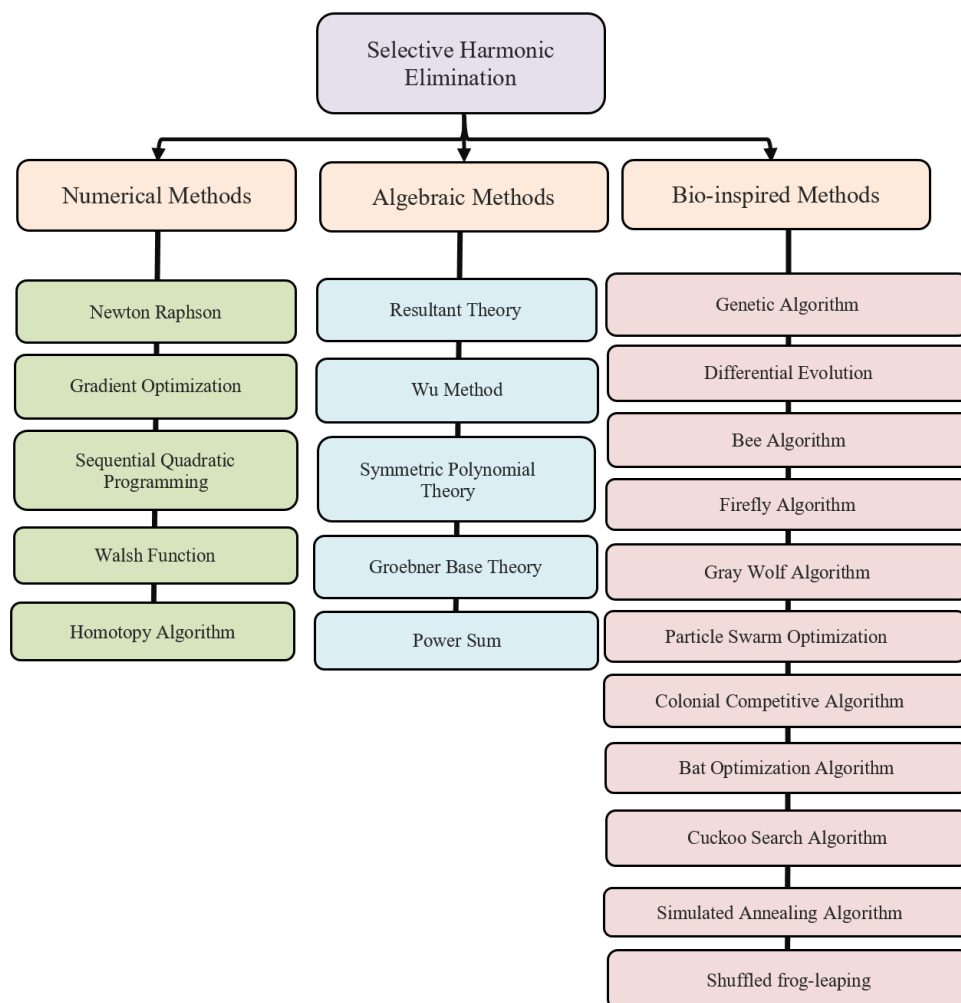

Fig. 1. SHE techniques with different methods

algorithms and objective functions were suggested by researchers, such as Genetic Algorithm (GA) [29], Differential Evolution (DE) [30], Bee Algorithm (BA) [31], Particle Swarm Optimization (PSO) [32,33], Imperialist Competitive Algorithm (ICA) [34], Firefly Algorithm (FA) [8], Bat Optimization Algorithm (BOA) [35], Cuckoo Search Algorithm [36], Simulated Annealing (SA) [37], Shuffled Frog Leaping Algorithm (SFLA) [38], and Grey Wolf Optimizer (GWO) algorithm [39].

Since according to No Free Lunch (NFL) theory [40] not every meta-heuristic algorithm is able to accurately solve engineering problems, some special optimization algorithms may could solve a number of these problems, however have difficulties in solving some other problems. For this reason, it is suggested to apply new optimization methods for solving optimization problems. Therefore, in this paper a recent developed meta-heuristic method is used to reduce THD and eliminate selective harmonics in multi-level inverters. The proposed new method is called Salp Swarm Algorithm (SSA), introduced by Mirjalili and et al. in 2017 [41]. This algorithm has an inspiration from social behavior and chain-like movement of a swarm of salps. Salp chain has the ability to move toward the global optimum that changes during the iterations, and finally reach the optimal solution. The advantages of the SSA algorithm in solving optimization problems can be arranged in the following order: easy implementation, simplicity, high convergence speed, only one tuning parameter (C1), exploitation in the search space and then utilizing it during the iterations, passing through the local minima with regard to updating the positions of Leader and Follower sulps with respect to the food position and each other.

In the proposed method, the magnitudes of harmonic waveforms, which are to be reduced or eliminated, are selected by calculating Fourier series expansion of the sinusoidal signal, and then expressed as an objective function. Next, the angles that reduce the objective function and remove the harmonics are optimally determined by the optimization algorithm. The method is applied to a CHB-MLI to reduction of THD and selection of the optimal switching angle performed by SSA optimization algorithm. The presented method is compared with classic SPWM and PSO based SHE-SPWM algorithms.

The rest of the paper is organized as follows: Section 2 presents CHB-MLI modeling, Fourier relations and

SHE basic equations. Section 3 focuses on the proposed method for calculating optimized angles and introduces SSA algorithm, also objective function of SHE with constraint are calculation . Section 4 introduces the system under study and simulation results. Section 5 concludes the paper.

## 2. SHE FOR CHB MULTI-LEVEL INVERTER

The main circuit of an  $m$ -level CHM-MLI is shown in Fig. 2. The circuit consists of  $(m-1)/2$  unit at each phase that are connected in series. Each units includes a single-phase H-bridge inverter with a separate DC source. Also each unit has four active switches which provide three voltage leveles, i.e.,  $0$ ,  $+V_{dc}$ ,  $-V_{dc}$ . When S1 and S4 switches of an H-bridge inverter are closed, the output voltage is  $+V_{dc}$ , and in the case S2 and S3 switches are closed, the output voltage is equal to  $-V_{dc}$ . Furthermore, if S3 and S1 switches or S2 and S4 switches are closed, then the output voltage will be zero. Higher voltage levels can also be obtained through cascades configuration of these units. The phase voltgae,  $V_{an}$ , in a CHB-MLI is equal to the sum of voltages of individual units [32].

$$V_{an} = V_1 + V_2 + V_3 + \dots + V_m \quad (1)$$

where  $V_1, V_2, V_3, \dots, V_m$  are output voltages of the units. The output waveforms of the CHB-MLI inverter are shown in Fig. 3. The following relationship can be written in terms of Fourier series expansion:

$$V(t) = \sum_{n=1}^{\infty} (a_n \sin n\alpha_n + b_n \cos n\alpha_n) \quad (2)$$

where  $\alpha_n$  coefficient is:

$$a_n = \frac{4V_{dc}}{n\pi} \sum_{k=1}^m (\cos n\alpha_k) \quad (3)$$

where  $\alpha_k$  are switching angles that should be optimally determined in the selective harmonics elimination problem. These switching angles should satisfy the following conditions:

$$0 < \alpha_1 < \alpha_2 < \dots < \alpha_m < \frac{\pi}{2} \quad (4)$$

Due to the symmetry of one fourth of the output voltage, odd harmonics will be zero ( $b_n = 0$ ).

By using selective harmonic elimination method, to cancel 3-th and 5-th harmonic in the voltage signal, for a single phase seen-level inverter below equations can be written as:

$$\frac{1}{3} [\cos(\alpha_1) + \cos(\alpha_2) + \cos(\alpha_3)] = M \quad (5)$$

$$M = \frac{\pi V_{Desired}}{4N_{dc} V_{dc}} \quad , \quad 0 < M \leq 1 \quad (5) \text{--} \text{continue}$$

$$\cos(3\alpha_1) + \cos(3\alpha_2) + \cos(3\alpha_3) = 0 \quad (6)$$

$$\cos(5\alpha_1) + \cos(5\alpha_2) + \cos(5\alpha_3) = 0 \quad (7)$$

where  $V_{Desired}$  and  $N_{dc}$  denote output desired phase voltage and number of DC sources, respectively.

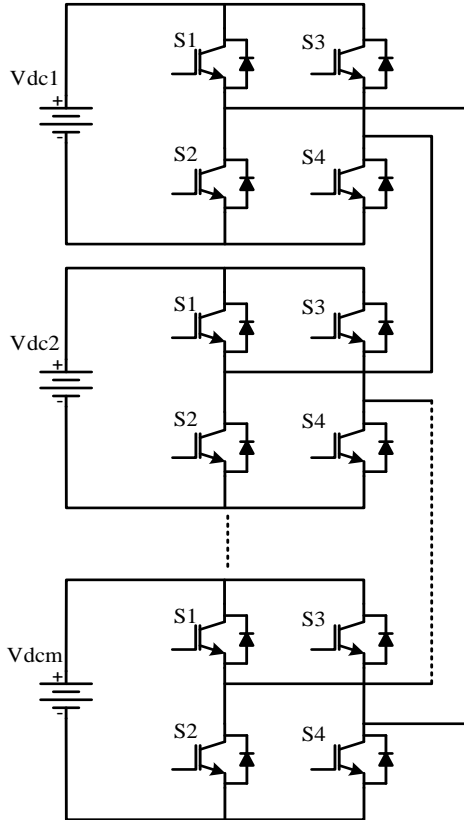

Fig. 2. Single-phase cascaded m-level inverter

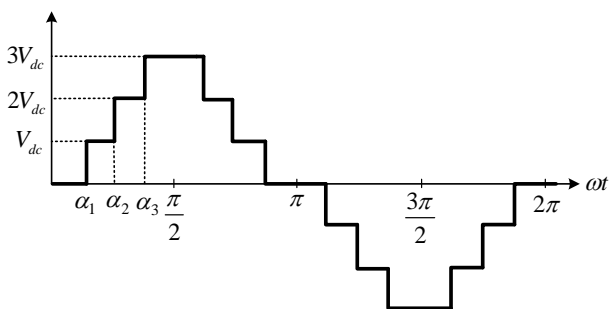

Fig. 3. The output waverform of CHB-MLI.

### 3. PROPOSED OPTIMIZAED SWITCHING METHOD

In this section of the paper, the proposed optimization method for solving the optimization problem is introduced and the calculation approach of the objective function is explained thoroughly to find the optimal angles so as to eliminate the selective harmonics and reduce the THD value.

### 3.1. Salp Swarm Optimization Algorithm

Salp swarm optimization algorithm (SSA) was first introduced by Mirjalili and et al. in 2017 according to the social behavior of salps [41]. Salps belong to a family of Salpidae that have transparent and tubular body. The texture of their bodies is much like jellyfish and they move very similar to jellyfish; the water is pumped through their bodies to provide the propelling force. Fig. 4 shows the figure of a salp in both individual and group forms.

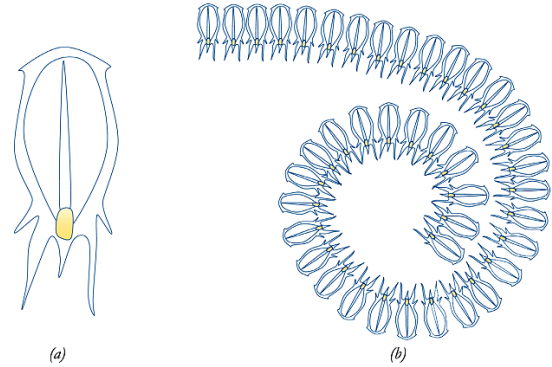

Fig. 4. (a) An individual salp, (b) a group of salps (a salp string).

To model the SSA, the social and string-like behavior of Salps to get a better motion and stir is exploited for fast coordinated changes and foraging applications. To mathematically model the Salp strings, first, the population is divided into two groups: the leader and the followers. The leader of the group is the Salp in the front end of the string, and other Salps are considered as the followers. As the name of these slaps suggest, the leader in fact leads and guides the group and the followers (directly or indirectly) follow one another. Similar to other swarm-based methods, Salp positions are defined in an  $n$ -dimension search space, where  $n$  is the number of variables in a specific problem. So, the positions of all Salps are stored in a 2-D matrix, named  $\mathbf{x}$ . Also, it is assumed that there is a food source,  $\mathbf{F}$ , in the search space as the objective of the swarm. To update the leader's position, the following equation is employed:

$$x_j^1 = \begin{cases} F_j + c_1 \times ((ub_j - lb_j) \times c_2 + lb_j) & c_3 \geq 0 \\ F_j - c_1 \times ((ub_j - lb_j) \times c_2 + lb_j) & c_3 < 0 \end{cases} \quad (8)$$

where  $x_j^1$  shows the position of the first Salp (leader) in the  $j$ -th dimension,  $F_j$  is the position of food source in the  $j$ -th dimension,  $ub_j$  is the upper boundary of the  $j$ -th dimension,  $lb_j$  is the lower boundary of the  $j$ -th dimension. Also,  $c_1$ ,  $c_2$ , and  $c_3$  are random numbers. Eq. (8) shows that only the leader updates its position with respect to the food source. Coefficient  $c_1$  is the most important parameter in SSA because it balances the following defined exploration and exploitation:

$$c_1 = 2e^{-\left(\frac{4l}{L}\right)^2} \quad (9)$$

where  $l$  is the current iteration and  $L$  is the maximum number of iterations. Parameters  $c_2$  and  $c_3$  are random numbers generated uniformly in the range of  $[0, 1]$ . In fact, these show whether the next position in the  $j$ -th dimension should be towards the positive or negative infinity, and determine the step size. The following equations are used to update the positions of followers (Newton's motion law):

$$x_j^i = \frac{1}{2}a \times t + v_0 \times t \quad (10)$$

where  $i \geq 2$ ,  $x_j^i$  shows the position of the  $i$ -th leader salp in the  $j$ -th dimension,  $t$  is the time,  $v_0$  represents the initial velocity, and  $a = \frac{v_{final}}{v_0}$ , and  $v = \frac{x - x_0}{t}$ , because the time

in the optimization process is the iteration. The difference between the iterations is 1, and considering  $v_0 = 1$ , the equation can be written as:

$$x_j^i = \frac{1}{2}(x_j^i + x_j^{i-1}) \quad (11)$$

where  $i \geq 2$ ,  $x_j^i$  shows the position of the  $i$ -th leader salp in the  $j$ -th dimension. Salp strings can be simulated by using (8) and (11). The flowchart of SSA is given in Fig. 5 [41].

### 3.2. Objective Function

To solve the selective harmonics elimination problem, Fourier series expansion can be used. Fourier series expansion for the original signal and its coefficients was explained in Section 2. In this paper, the number of levels for the inverter is set to five. As a consequence, two angles are required to be determined for the switching purpose ( $\alpha_i$  ( $i = 1, 2, \dots, \frac{(n-1)}{2}$ )). In this section, other odd harmonics that should be also chosen are expressed as (12)-(17).

$$V_1' = \cos(\alpha_1) + \cos(\alpha_2) \quad (12)$$

$$V_3' = \cos(3\alpha_1) + \cos(3\alpha_2) \quad (13)$$

$$V_5' = \cos(5\alpha_1) + \cos(5\alpha_2) \quad (14)$$

$$V_7' = \cos(7\alpha_1) + \cos(7\alpha_2) \quad (15)$$

$$V_{11}' = \cos(11\alpha_1) + \cos(11\alpha_2) \quad (16)$$

$$V_{13}' = \cos(13\alpha_1) + \cos(13\alpha_2) \quad (17)$$

where  $V_1'$  is the desired voltage and  $V_3', V_5', V_7', V_{11}', V_{13}'$  are lower order harmonics where their values are equal to zero. Regarding the (12)-(17), the objective function for the harmonic elimination problem is considered as (18).

$$O.F = \omega_1 \left| V_1' - \left( \frac{n-1}{2} \right) M \right| + \omega_2 \sum_{k=2m+1}^{13} |V_{2m+1}'| + \omega_3 THD \quad (18)$$

$$THD = \frac{\sqrt{\sum_{n=2}^{13} V_n'^2}}{V_1'} \quad (19)$$

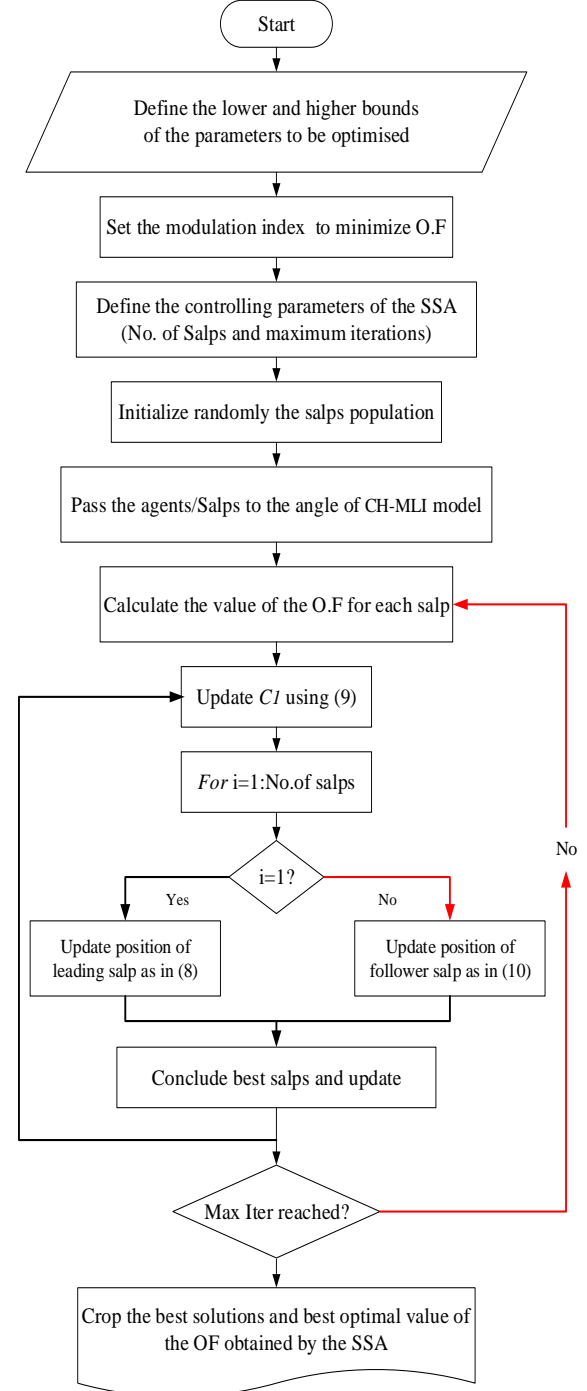

Fig. 5. The main flowchart of the Salp Swarm Algorithm (SSA).

In the above equation,  $m = 1, 2, \dots, 6$  are chosen for selective odd harmonics,  $M$  denotes the modulation index, and  $\omega_i$  are positive weighting factors. The values of these factors are set equal to 1, 4 and 1. These numbers are determined by their range of value, degree of importance and empirically determined by the implementation of the optimization algorithm and the resulting response. The optimization problem which is defined as (20) is optimized by SSA and  $\alpha_1$  and  $\alpha_2$  angles are optimized in terms of different demodulation indexes.

Minimize  $O.F(\alpha_1, \alpha_2)$

subject to :

$$\begin{aligned} 0 &\leq \alpha_1 \leq \pi/2 \\ 0 &\leq \alpha_2 \leq \pi/2 \\ \alpha_1 &\neq \alpha_2 \\ \alpha_1 &< \alpha_2 \end{aligned} \quad (20)$$

### 3.3. Implementation of salp swarm algorithm for SHE

According to SSA algorithm, steps of finding switching angles for SHE problem are summarized as follows:

**Step 1.** Define input data of the studied system and upper and lower boundary parameters of the switching angles ( $x_{min}$ -  $x_{max}$ ).

**Step 2.** Define the number of search agents ( $N$ ), maximum number of iterations ( $iter-max$ ).

**Step3.** Initialise the Salp population matrix( $X$ ). In this matrix, each population set represents the position of a search agent. From the optimization point of view, position of a search agent signifies one of candidates for minimization of the objective function. In the proposed objective function, position of each search agent consists of the two unspecific parameters of the switching angle (i.e  $\alpha_2, \alpha_1$ ). Each elements of the position of search agent is initialized within the limits of parameters of the switching angles and may be determined as

$$x_{m,j} = x_{m,j}^{\min} + rand(0,1) \times (x_{m,j}^{\max} - x_{m,j}^{\min}) \quad (21)$$

where  $x_{m,j}$  is  $j$ th element of  $m$ th search agent position. Here  $m=1,2,\dots,N$  and  $j=1,2,\dots, D$ . Here  $N$  is the maximum number of the search agents and  $D$  is the number of variable in the problem (in the proposed objective function  $D=2$ ). According to above explanations, matrix  $X$  can be presented as flowing way.

$$X = \begin{bmatrix} X_1 \\ X_2 \\ \cdot \\ \cdot \\ \cdot \\ X_N \end{bmatrix} = \begin{bmatrix} x_{1,1} & x_{1,2} \\ x_{2,1} & x_{2,2} \\ \cdot & \cdot \\ \cdot & \cdot \\ \cdot & \cdot \\ x_{N,1} & x_{N,2} \end{bmatrix} \quad (22)$$

Position of each search agent should satisfy constraints of parameters of switching angles.

**Step 4.** Calculate the objective function (Eq. 18) value of each search agent.

**Step 6.** Select best objective function as leader and leader position respectively (Food position).

**Step 7.** Set iteration number  $iter=1$ .

**Step 8.** Update C1 using (Eq. 6)

**Step 9.** Update position of leading Salp as in (Eq. 8)

**Step 10.** Update position of follower Salp as in (Eq. 10)

**Step 11.** Check constraints limits for each search agent if constraints limits are satisfied, then go to the next step, otherwise replace search agent position with boundaries of the search space ( $x_{min}$ -  $x_{max}$ ).

**Step 12.** Calculate the objective function (Eq. 18) value of each search agent.

**Step 13.** Select best objective function as leader and leader position respectively (Food position).

**Step 14.** Increase iteration number by 1, that is,  $iter=iter+1$ .

**Step 15.** If the maximum number of iteration is reached, stop the iterative process and store food position as the best solution of the optimization problem (switching angles), otherwise go step 8.

## 4. SIMULAION RESULTS

In this section, a three-phase CHB-MLI with resistive-inductive load is taken into account to show the efficacy of SSA in solving SHE optimization problem. The inverter is a five-level inverter, therefore two optimal angles are specified by the algorithm. The five-level inverter with 11 kV output voltage, 50 Hz along with a 50 resisitve, 50 mH inductive load is simulated via MATLAB/Simulink. The structure of the inverter alongside the switches is illustrated in Fig. 6. As seen, two cascaded H-bridge inverters are used to establish a five-level inverter. To compare the employed switching technique, simulations are performed for two study cases, i.e., I. Simulation of SPWM-MLI, and II. Simulation of

SHE-MLI.

#### 4.1. Simulation of SPWM-MLI

SPWM pulse generation method is used for simulating SPWM-MLI technique. The carrier signal frequency is assumed 1.5 kHz. The reference sinusoidal waveform together with the carrier signal waveform for SPWM-MLI are shown in Fig. 7. Furthermore, the output line voltage for the load can be seen in Fig. 8, where the output waveform using the multi-level inverter is almost similar to the sinusoidal waveform. In this method, the amount of THD for modulation index of 1.2 with Fourier analysis for the output voltage is calculated and then shown in Fig. 9, where its value is 7.56%.

#### 4.2. Simulation of SHE-MLI

In this paper, SHE method is utilized for elimination of selective harmonics in an MLI inverter. With regard to the number of levels, two optimal angles are required which are optimally determined by an optimization algorithm. The considered objective function in Section 3 of the paper is employed for this problem. PSO and SSA algorithms are used in this section to solve SHE problem and remove harmonics of order 5-7-11-13.

The adjustment parameters of these algorithms are listed in Table 1. First, the modulation index is specified and based on that the angles are determined through the algorithm. The structure of the considered inverter for SHE-MLI case is similar to that of SPWM-MLI. The output line voltage waveform for a modulation index of 1.2 is provided in Fig. 10. Also the generated pulses by SHE-MLI part are shown in Fig. 11. In this modulation factor, the optimal angles are obtained equal to  $\alpha_1=7.6505$  and  $\alpha_2=24.0778$ . Harmonics analysis of the output line voltage for this case is given in Fig. 12, where THD value for demodulation index of 1.2 using the PSO algorithm

presented in [32] is 2.81%, while it is 2.32% in the proposed SSA algorithm. These results prove that using SHE method for MLI inverters reduces THD and improves power quality.

It should be noted that the optimized angles ( $\alpha_1, \alpha_2$ ) are calculated for phase voltage of a five-level cascaded H-bridge MLI and the results are presented for its output line voltages. There is a linear relation between phase voltage THD and line voltage THD for a specific MLI. Because the line voltage has higher levels in comparison with the phase voltage in same MLI, the Line voltage THD will be smaller than phase voltage THD. Fig. 13 shows Inverter's output phase voltage waveform for  $m=1.2$  by SSA-SHE-MLI method while its harmonic spectrum is presented in Fig. 14. As discussed heretofore, the THD value for phase voltage of MLI is equal to 6.13% and this value is bigger than line voltage THD. Also there is considerable third harmonic component in phase voltage harmonic spectrum while this component disappears in line voltage harmonic spectrum which is predictable.

#### 4.3. Comparison Results

In this section, THD value is evaluated for different values of modulation index so as to compare the performances of SPWM, PSO-SHE-MLI, and SSA-SHE-MLI methods. Simulation results for different modulation indexes are given in Table 2. This table lists THD values for the mentioned three methods along with the optimal angles of SSA method. According to the results, it is seen that SSA method has the lowest THD value for different modulation indexes. Moreover, using SHE reduces the THD value. The convergence curves of both PSO and SSA algorithms for  $m = 1.2$  are presented in Fig. 15.

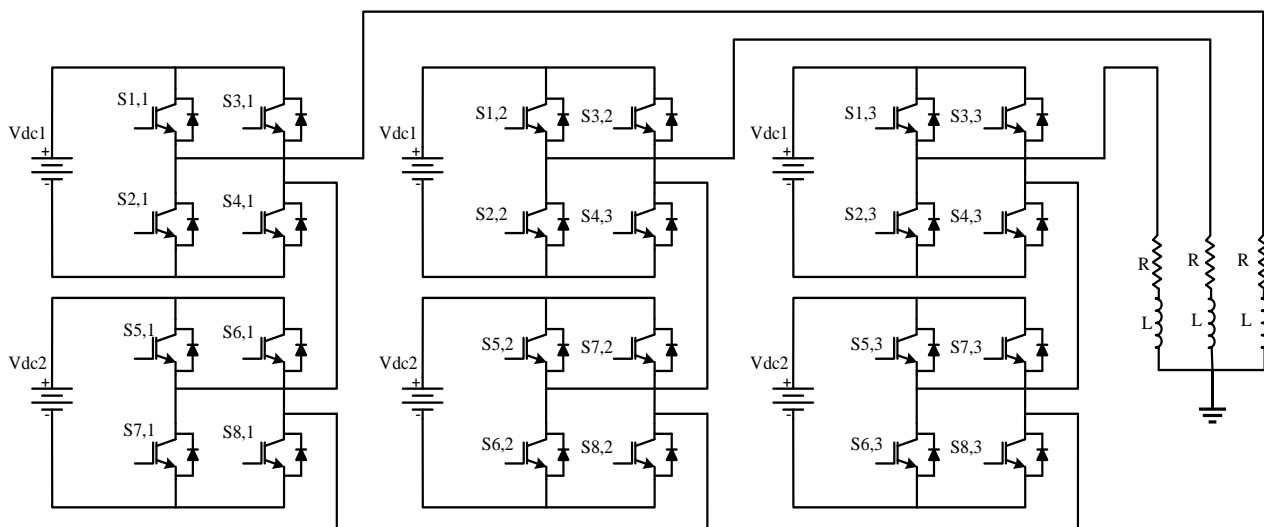

Fig. 6. The structure of CHB-MLI multi-level inverter

According to Fig. 15 one can observe that SSA has higher convergence speed compared to PSO algorithm and the value of objective function is smaller. The reduction amount of THD value with respect to increasing modulation index from 0.85 to 1.2 for three methods are shown in Fig. 16, where by increasing the modulation index, THD value is reduced and this reduction is intensified with SSA method even more.

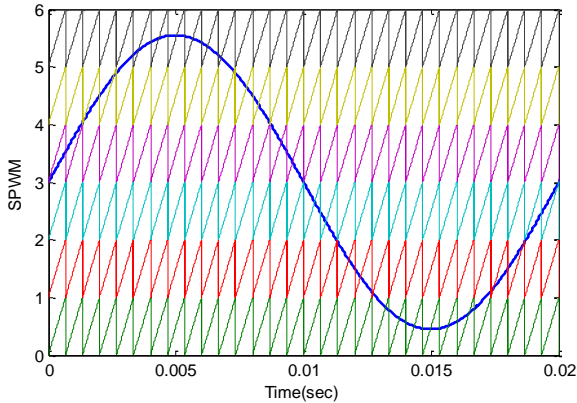

Fig. 7. The reference and carrier signals waveforms with SPWM method for a multi-level inverter

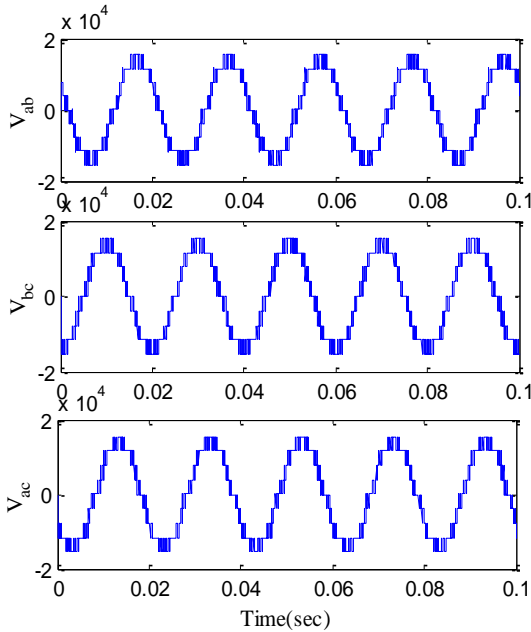

Fig. 8. The output line voltage of SPWM multi-level inverter for m=1.2

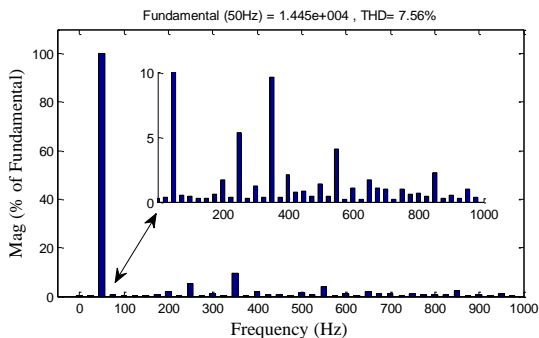

Fig. 9. Harmonics analysis of the output line voltage of a SPWM multi-level inverter for m = 1.2

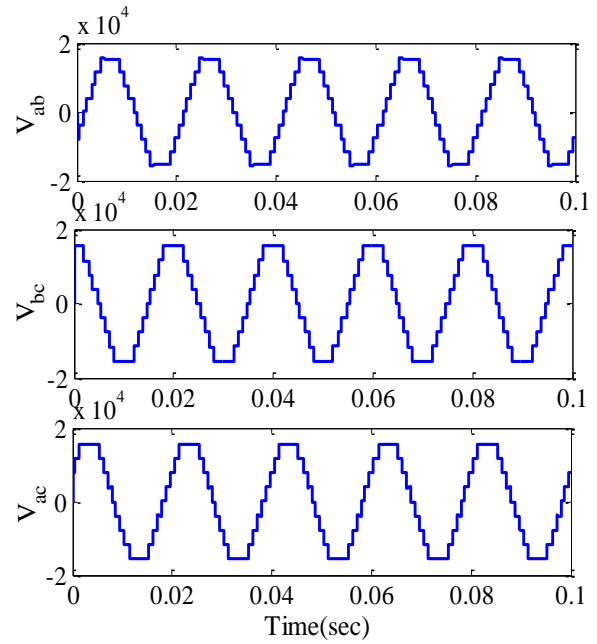

Fig. 10. Inverter's output line voltage waveform for m = 1.2 by SSA-SHE-MLI method

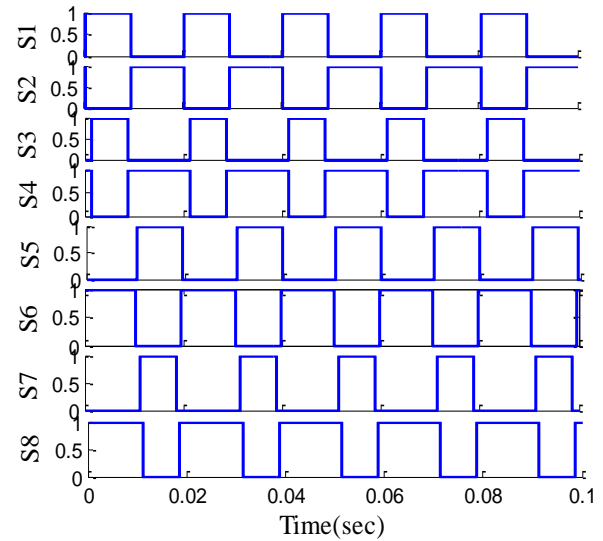

Fig. 11. The generated pulse by SHE-MLI method for m = 1.2

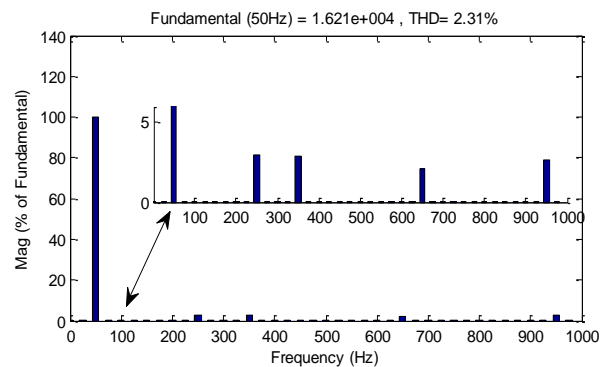

Fig. 12. Harmonics analysis of the inverter's output line voltage by SSA-SHE-MLI method



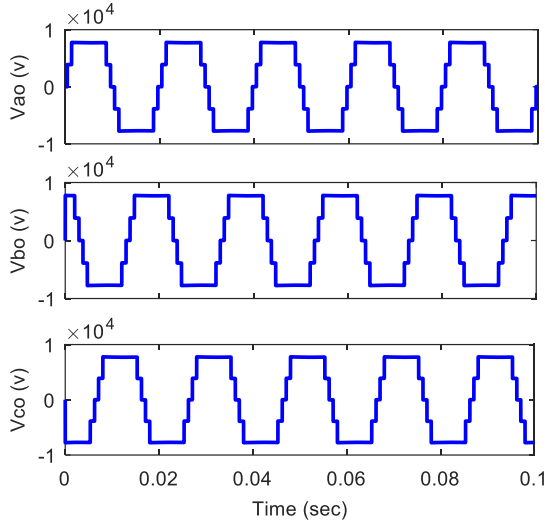

Fig. 13. Inverter's output phase voltage waveform for  $m = 1.2$  by SSA-SHE-MLI method

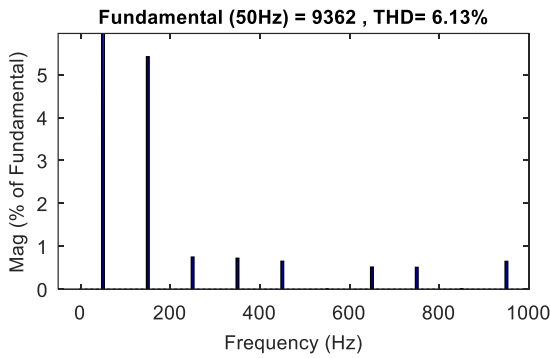

Fig. 14. Harmonics analysis of the inverter's output phase voltage by SSA-SHE-MLI method

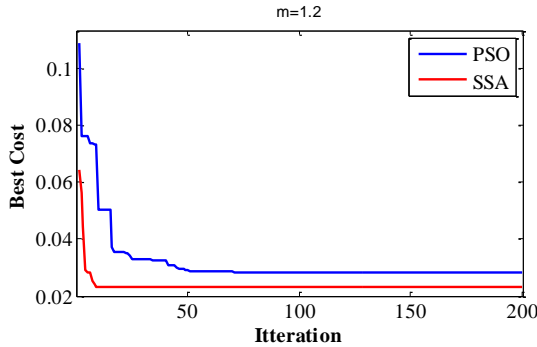

Fig. 15. The convergence curve of both SSA and PSO algorithms for  $m = 1.2$

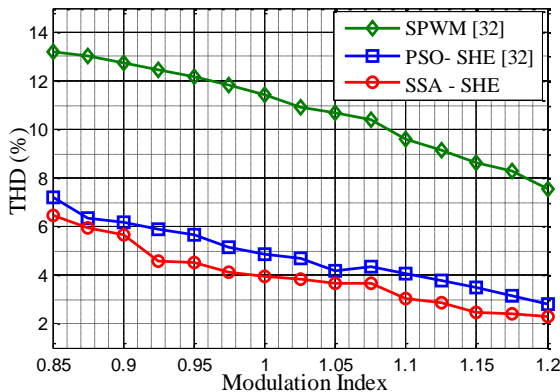

Fig. 16. THD percentage variation with respect to variations of demodulation index in MLI

Table 1. Parameters of PSO and SSA algorithms

Parameter	PSO	SSA
Maximum number of iterations	200	200
Number of population	100	100
$c_1, c_2$	2	--

Table 2. The comparison of THD percentage values with respect to modulation factor variations

Modulation Index	SPWM	PSO[32]	SSA	SSA	
	THD (%)			$\alpha_1$ (deg)	$\alpha_2$ (deg)
0.850	13.21	7.21	<b>6.46</b>	36.18	86.11
0.875	13.04	6.34	<b>5.92</b>	36.48	84.49
0.900	12.76	6.17	<b>5.67</b>	36.40	83.09
0.925	12.48	5.91	<b>4.60</b>	11.25	89.99
0.950	12.16	5.68	<b>4.54</b>	10.58	52.47
0.975	11.84	5.13	<b>4.13</b>	9.473	47.34
1.000	11.41	4.84	<b>3.92</b>	33.75	59.99
1.025	10.94	4.69	<b>3.84</b>	9.215	13.77
1.050	10.69	4.18	<b>3.67</b>	9.240	44.99
1.075	10.38	4.34	<b>3.65</b>	9.248	44.99
1.100	9.610	4.04	<b>3.05</b>	11.24	29.99
1.125	9.150	3.76	<b>2.85</b>	6.923	18.42
1.150	8.640	3.48	<b>2.45</b>	9.951	25.71
1.175	8.270	3.16	<b>2.39</b>	8.571	22.24
1.200	7.560	2.81	<b>2.31</b>	7.650	24.07

### 5. CONCLUSIONS

Multi-level inverters have a great number of advantages like small THD value and sinusoidal-like output waveform. In addition, using SHE switching technique in this type of inverters significantly reduces the switching loss and THD percentage value. To this end, SHE technique is used in this paper for switching purposes in CHB-MLI inverter. To reach this aim and also determine the optimal switching angles, a recent developed meta-heuristic algorithm called SSA, which is an inspiration by Salp swarm, is employed in this study. The proposed approach is implemented on a five-level CHB-MLI inverter. The obtained results by SSA are compared with those of meta-heuristic PSO method and SPWM technique. The optimization results show that the performance of SSA is superior than that of PSO in solving SHE optimization problem. Additionally, after carrying out harmonics analysis (FFT) of the inverter's output voltage, the THD percentage value in SSA method is smaller than those in other two methods for different modulation indexes. Therefore, using SSA method reduces harmonic distortion, improves switching frequency conditions and output voltage quality, and enhances power quality.

## REFERENCES

- [1] J.-S. Lai, F.Z. Peng, "Multilevel converters-a new breed of power converters," *Proce. IEEE Ind. Appl. Conf. 1995. Thirtieth IAS Annu. Meet. IAS'95., Conf. Rec. 1995 IEEE*, 1995, pp. 2348-2356.
- [2] J. Rodriguez, J.-S. Lai, F.Z. Peng, "Multilevel inverters: a survey of topologies, controls, and applications," *IEEE Trans. Ind. Electron.* vol. 49, pp. 724-738, 2002.
- [3] M.M. Rahimian, M. Hosseinpour, A. Dejamkhooy, "A modified phase-shifted pulse width modulation to extend linear operation of hybrid modular multi-level converter," *J. Oper. Autom. Power Eng.*, vol. 6, no. 2, pp. 183-192, 2018.
- [4] N. Rasekh, M.M. Rahimian, M. Hosseinpour, A. Dejamkhooy, A. Akbarimajid, "A step by step design procedure of PR controller and capacitor current feedback active damping for a LCL-type grid-tied T-type inverter," *Proce. 2019 10<sup>th</sup> Int. Power Electron. Drive Syst. Tech. Conf. (PEDSTC)*, 2019, pp. 612-617.
- [5] S.G. Ardakani, M. Hosseinpour, M. Shahparasti, M. Siah, "Direct torque control of low-voltage three-phase induction motor using a three-level eight-switch inverter," *Arab. J. Sci. Eng.*, Early access, 2019.
- [6] M. Farhadi Kangarlu, E. Babaei, and F. Blaabjerg, "An LCL-filtered single-phase multilevel inverter for grid integration of pv systems," *J. Oper. Autom. Power Eng.*, vol. 4, no. 1, pp. 54-65, 2016.
- [7] M.G. Sundari, M. Rajaram, S. Balaraman, "Application of improved firefly algorithm for programmed PWM in multilevel inverter with adjustable DC sources," *Appl. Soft Comput.*, vol. 41, pp. 169-179, 2016.
- [8] A. Nabae, I. Takahashi, H. Akagi, "A new neutral-point-clamped PWM inverter," *IEEE Trans. Ind. Appl.*, pp. 518-523, 1981.
- [9] T.A. Meynard, H. Foch, "Multi-level choppers for high voltage applications," *EPE J.*, vol. 2, pp. 45-50, 1992.
- [10] K. Corzine, Y.L. Familiant, "A new cascaded multilevel H-bridge drive," 2002.
- [11] M. Hosseinpour, M. Mohamadian, A. Yazdian Varjani, "Design and analysis of the droop-controlled parallel four-leg inverters to share unbalanced and nonlinear loads," *Przeegląd Elektrotechniczny*, vol. 90, no. 1, pp. 105-110, 2014.
- [12] M. Hosseinpour, A. Dejamkhooy, "Control and power sharing among parallel three-phase three-wire and three-phase four-wire inverters in the presence of unbalanced and harmonic loads," *IEEE Trans. Electr. Electron. Eng.*, vol. 13, no. 7, pp. 1027-1033, 2018.
- [13] S. Kouro, J. Rebolledo, J. Rodríguez, "Reduced switching-frequency-modulation algorithm for high-power multilevel inverters," *IEEE Trans. Ind. Electron.* vol. 54 pp. 2894-2901, 2007.
- [14] M.S.A. Dahidah, G. Konstantinou, V.G. Agelidis, "A review of multilevel selective harmonic elimination PWM: formulations, solving algorithms, implementation and applications," *IEEE Trans. Power Electron.*, vol. 30, pp. 4091-4106, 2015.
- [15] H.S. Patel, R.G. Hoft, "Generalized techniques of harmonic elimination and voltage control in thyristor inverters: Part I--Harmonic Elimination," *IEEE Trans. Ind. Appl.*, pp. 310-317, 1973.
- [16] H.S. Patel, R.G. Hoft, "Generalized techniques of harmonic elimination and voltage control in thyristor inverters: part II--voltage control techniques," *IEEE Trans. Ind. Appl.*, pp. 666-673, 1974.
- [17] K. Yang, Z. Yuan, R. Yuan, W. Yu, J. Yuan, J. Wang, "A Groebner bases theory-based method for selective harmonic elimination," *IEEE Trans. Power Electron.*, vol. 30, pp. 6581-6592, 2015.
- [18] M.A. Memon, S. Mekhilef, M. Mubin, M. Aamir, "Selective harmonic elimination in inverters using bio-inspired intelligent algorithms for renewable energy conversion applications: A review," *Renew. Sustain. Energy Rev.*, vol. 82, pp. 2235-2253, 2018.
- [19] T.-J. Liang, R.M. O'Connell, R.G. Hoft, "Inverter harmonic reduction using Walsh function harmonic elimination method," *IEEE Trans. Power Electron.* vol. 12 pp. 971-982, 1997.
- [20] J. Kumar, B. Das, P. Agarwal, "Harmonic reduction technique for a cascade multilevel inverter," *Int. J. Recent Trends Eng.*, vol. 1, no. 3, pp. 181, 2009.
- [21] G.H. Aghdam, "Optimised active harmonic elimination technique for three-level T-type inverters," *IET Power Electron.*, vol. 6, pp. 425-433, 2013.
- [22] G.T. Son, Y.-H. Chung, S.-T. Baek, H.J. Kim, T.S. Nam, K. Hur, et al., "Improved PD-PWM for minimizing harmonics of multilevel converter using gradient optimization," *Proce. PES Gen. Meet. Conf. Expo. 2014 IEEE, IEEE*, 2014, pp. 1-5.
- [23] J. Sun, H. Grotstollen, "Solving nonlinear equations for selective harmonic eliminated PWM using predicted initial values," *Proce. Ind. Electron. Control. Instrumentation, Autom. 1992. Power Electron. Motion Control. Proc. 1992 Int. Conf., IEEE*, 1992, pp. 259-264.
- [24] K. Imarazene, H. Chekireb, "Selective harmonics elimination PWM with self-balancing DC-link in photovoltaic 7-level inverter," *Turkish J. Electr. Eng. Comput. Sci.*, vol. 24, pp. 3999-4014, 2016.
- [25] K. Yang, Q. Zhang, R. Yuan, W. Yu, J. Yuan, J. Wang, "Selective harmonic elimination with Groebner bases and symmetric polynomials," *IEEE Trans. Power Electron.*, vol. 31, pp. 2742-2752, 2016.
- [26] J.N. Chiasson, L.M. Tolbert, K.J. McKenzie, Z. Du, "Elimination of harmonics in a multilevel converter using the theory of symmetric polynomials and resultants," *IEEE Trans. Control Syst. Technol.*, vol. 13, pp. 216-223, 2005.
- [27] C.-F. Zheng, B. Zhang, "Application of Wu method to harmonic elimination techniques," *Proce. Zhongguo Dianji Gongcheng Xuebao(Proc. Chin. Soc. Electr. Eng.)*, 2005, pp. 40-45.
- [28] J.N. Chiasson, L.M. Tolbert, Z. Du, K.J. McKenzie, "The use of power sums to solve the harmonic elimination equations for multilevel converters," *EPE J.*, vol. 15, pp. 19-27, 2005.
- [29] B. Ozpineci, L.M. Tolbert, J.N. Chiasson, "Harmonic optimization of multilevel converters using genetic algorithms," *Proce. 2004 IEEE 35th Annu. Power Electron. Spec. Conf. (IEEE Cat. No.04CH37551)*, IEEE, 2004, pp. 3911-3916. doi:10.1109/PESC.2004.1355167.
- [30] A.M. Amjad, Z. Salam, A.M.A. Saif, "Application of differential evolution for cascaded multilevel VSI with harmonics elimination PWM switching," *Int. J. Electr. Power Energy Syst.*, vol. 64, pp. 447-456, 2015.
- [31] A. Kavousi, B. Vahidi, R. Salehi, M.K. Bakhshizadeh, N. Farokhnia, S.H. Fathi, "Application of the bee algorithm for selective harmonic elimination strategy in multilevel inverters," *IEEE Trans. Power Electron.*, vol. 27, pp. 1689-1696, 2012.
- [32] V.K. Gupta, R. Mahanty, "Optimized switching scheme of cascaded H-bridge multilevel inverter using PSO," *Int. J. Electr. Power Energy Syst.*, vol. 64, pp. 699-707, 2015.

- [33] S. Sudha Letha, T. Thakur, J. Kumar, "Harmonic elimination of a photo-voltaic based cascaded H-bridge multilevel inverter using PSO (particle swarm optimization) for induction motor drive," *Energy*, vol. 107, pp. 335-346, 2016.
- [34] A. Ajami, M.R.J. Oskuee, A. Mokhberdorran, H. Shokri, "Selective harmonic elimination method for wide range of modulation indexes in multilevel inverters using ICA," *J. Cent. South Univ.*, vol. 21, pp. 1329-1338, 2014.
- [35] K. Ganesan, K. Barathi, P. Chandrasekar, D. Balaji, "Selective Harmonic Elimination of Cascaded Multilevel Inverter Using BAT Algorithm," *Procedia Technol.*, vol. 21, pp. 651-657, 2015.
- [36] N.V. Kumar, V.K. Chinnaiyan, M. Pradish, M.S. Divekar, "Selective harmonic elimination: An comparative analysis for seven level inverter," *Proce. 2016 IEEE Students' Technol. Symp., IEEE*, 2016, pp. 157-162.
- [37] N.V. kumar, V.K. Chinnaiyan, M. Pradish, S.P. Karthikeyan, "Simulated Annealing Based Selective Harmonic Elimination for Multi-level Inverter," *Energy Procedia*, vol. 117, pp. 855-861, 2017.
- [38] J. Lu, C. Mao, L. Wang, H. Lou, D. Wang, "Fundamental modulation strategy with selective harmonic elimination for multilevel inverters," *IET Power Electron.* vol. 7 pp. 2173-2181, 2014.
- [39] P.Q. Dzung, N.T. Tien, N. Dinh Tuyen, H.-H. Lee, "Selective harmonic elimination for cascaded multilevel inverters using grey wolf optimizer algorithm," *Proce. 2015 9th Int. Conf. Power Electron. ECCE Asia (ICPE-ECCE Asia), IEEE*, 2015, pp. 2776-2781.
- [40] D.H. Wolpert, W.G. Macready, "No free lunch theorems for optimization," *IEEE Trans. Evol. Comput.*, vol. 1, pp. 67-82, 1997.
- [41] S. Mirjalili, A.H. Gandomi, S.Z. Mirjalili, S. Saremi, H. Faris, S.M. Mirjalili, "Salp Swarm Algorithm: A bio-inspired optimizer for engineering design problems," *Adv. Eng. Softw.*, vol. 114, pp. 163-191, 2017.