

Research Paper

Analysis of Flashover Voltage of Porcelain and Glass Insulators under Different Temperatures with Various Levels of Pollution and Humidity

Reza Zahedi Khatir , Mohammad Mirzaie*  , and Hassan Mahdavi 

Faculty of Electrical and Computer Engineering, Babol Noshirvani University of Technology, Babol, Iran.

Abstract— Insulators of overhead transmission lines are continuously exposed to various environmental conditions. Factors such as pollution, humidity, temperature, and electrical stress negatively affect their performance. Environmental stresses can reduce surface resistance, increase leakage current, and ultimately lead to the flashover voltage of insulators. As a result, overhead transmission lines and some electrical equipment become disconnected from the power network. This can cause interruptions in energy transmission and reduce electrical grid reliability. In this paper, the flashover voltage of porcelain and glass insulators with artificial/natural pollution, as well as under clean conditions (non-pollution) and different levels of humidity and temperature, is measured, and the results are evaluated and analyzed. The experimental findings show that there is a mathematical correlation between the flashover voltage of the polluted insulators and the various levels of humidity and temperature. The coefficients of the model are determined in such a way that the results of the presented model are in good agreement. Besides, the experimental results indicate that the increase in temperature has a significant effect on the behavior of the insulators examined under different pollution and humidity conditions. The results show that the flashover voltage of the insulators decreases between 4% and 41% under constant pollution and humidity with different temperatures. It was also revealed that it is possible to estimate the flashover voltage of the insulators under different humidities using the correction factor of the flashover voltage.

Keywords—Porcelain and glass insulators, flashover voltage, pollution, humidity, temperature.

1. INTRODUCTION

Insulators are critical components in overhead transmission lines and high-voltage substations, typically exposed to outdoor environmental conditions. Their performance is significantly affected by external factors such as pollution, humidity, and temperature variations. Experimental studies have shown that non-uniform pollution, especially under electro-thermal stress, can drastically degrade the flashover performance of composite insulators, leading to increased leakage current and surface discharges [1]. Further research has highlighted that even RTV-coated porcelain insulators exhibit different aging behaviors depending on pollution severity and profile, which significantly affects their operational reliability [2]. In addition, flashover prediction indicators based on experimental tests have been proposed for porcelain and glass insulators, emphasizing the growing need for early fault diagnosis under polluted conditions [3]. The electrical flashover voltage performance of insulators under various environmental conditions has been extensively studied. In [4], an analytical investigation explored pollution flashover

characteristics of high-voltage outdoor insulators, demonstrating that equivalent salt deposit density (ESDD) significantly reduces flashover voltage under contaminated conditions. Furthermore, [5] examined AC flashover characteristics in haze-fog environments, revealing that smaller fog particle sizes and higher fog-water conductivity exacerbate voltage reduction. Additionally, [6] proposed an AC flashover voltage model for polluted suspension insulators in salt fog, indicating that increased ESDD levels lead to lower flashover voltages due to enhanced surface conductivity. Moreover, the impact of various contamination profiles on high-voltage insulators performance have been investigated in [7]. It has shown that non-soluble deposit density (NSDD) from mineral particles increases surface contamination without directly affecting electrical conductivity. In [8], the influence of pollution chemical components, such as calcium sulfate and sulfur dioxide, on insulator performance in fog conditions were evaluated and analyzed. Furthermore, the time and frequency characteristics and also harmonic analysis of leakage current on porcelain insulator string have been studied under different pollution locations and humidity with different applied voltages to the insulator [9]. Additionally, in [10] the flashover voltage of cap-pin insulators was measured under pollution condition, and the experiments showed that the increase pollution severity decreases the flashover voltage due to reduce the surface resistivity, compromising insulation capacity. This study was conducted under various pollution conditions using a real-world simulation. Furthermore, the FEM was utilized to simulate the insulator's behavior under polluted conditions. In [11], the flashover voltage of several porcelain insulators under different pollution distributions were evaluated. The experimental tests illustrated that the flashover voltage under all defined scenarios also varies with changes in the

Received: 11 Aug. 2024

Revised: 14 Jul. 2025

Accepted: 18 Jul. 2025

*Corresponding author:

E-mail: mirzaie@nit.ac.ir (M. Mirzaie)

DOI: 10.22098/joape.2025.15614.2201

This work is licensed under a [Creative Commons Attribution-NonCommercial 4.0 International License](https://creativecommons.org/licenses/by-nc/4.0/).

Copyright © 2025 University of Mohaghegh Ardabili.

humidity level, non-uniform pollution degree, and polluted surface area. In addition, an artificial neural network with a fuzzy logic model was used to predict the flashover voltage and condition of the insulators. Dynamic modeling approaches have also been developed to predict the characteristics of electric arcs around polluted insulators [12], providing insights into time-dependent arc behavior and supporting optimized insulator design. In addition, numerical methods have been proposed to estimate critical flashover voltage more accurately by considering pollution severity and environmental factors [13]. These contributions form a valuable foundation for understanding the combined impact of snow, ice, pollution, and environmental variations on the flashover voltage of high-voltage insulators. According to [14], experimental tests were carried out on several insulators, and the proposed dynamic model for the insulator's flashover voltage was investigated under fan-shaped pollution conditions. The influence of snowy and icy conditions on the flashover performance of insulators has been extensively studied. In [15], flashover voltage tests were conducted on snow-covered ceramic insulators under both natural and artificial pollution conditions, revealing that a higher equivalent salt deposit density (ESDD) in snowy environments significantly reduces the flashover electric field. This study highlighted the combined impact of snow thickness and pollution levels on insulator performance. Similarly, in [16], the effect of snow accretion on arc flashover gradients was investigated across various types of insulators, demonstrating that increased ESDD under snowy conditions markedly lowers the flashover voltage. The findings emphasized the critical role of snow characteristics in determining the reliability of insulators. Furthermore, in [17], the effects of atmospheric icing on power networks were analyzed, showing that thicker ice layers on snow-covered insulators absorb more moisture and are more difficult to melt, which can lead to higher flashover voltages. This study underscored the complex interaction between ice thickness and flashover behavior in snowy environments. In [18], electric field measurements were used to predict flashover voltage on clean and polluted insulators, highlighting the impact of surface conditions on insulation performance. Similarly, in [19], three-dimensional electric field simulations were conducted to analyze flashover paths on ice-covered suspension insulators, revealing how ice accumulation alters the electric field distribution. Moreover, in [20], a model for ice wet growth on composite insulators was developed and experimentally validated, showing its adverse effect on insulation performance. In addition, the authors in [21] have proposed a predictive model for dry-growth icing under natural conditions, emphasizing the influence of environmental factors such as humidity.

Furthermore, in [22], artificial intelligence techniques were applied to predict flashover voltage on polluted cap-pin insulators, resulting in improved accuracy under severe conditions. Additionally, in [23], the crystallization effect of conductive ions in freezing water was investigated, showing that ice bridge formation significantly reduces flashover voltage. In [24], a texture feature descriptor was introduced to identify natural ice types on glass insulators, aiding in the assessment of icing severity. Finally, in [25], a novel method using expanded conductors was devised to prevent ice-related disasters in power grids, effectively mitigating icing risks in regions prone to heavy ice accumulation. Collectively, these studies demonstrate that ice buildup—affected by factors such as wind speed, ice thickness, and conductive water films—significantly lowers flashover voltage, often due to the formation of ice bridges and surface moisture layers.

Other environmental conditions that affect the performance of insulators are air pressure and temperature. It has been shown in [26] that increasing altitude, as well as temperature, decreases the flashover voltage. The study in [27] investigates the flashover voltage of some insulators due to the effect of uniform and non-uniform distributions and high-speed airflow, based on the characteristics of high altitude. This study presented a theoretical basis and data to support the safety of high-speed rolling stock

in high-altitude areas. Furthermore, in [28], a pollution flashover test was investigated, and the dynamic behavior of the arc between insulator sheds was simulated to evaluate the impact of contamination and humidity on flashover voltage. Additionally, [29] examined the surface pollution flashover characteristics of RTV (room temperature vulcanizing) coated insulators under different coating damage modes. In [30], the authors investigated the effect of uniform and non-uniform pollution on the leakage current in polymeric insulators using the finite element method and circuit theory for analysis. In [31], many experimental tests were carried out on silicone rubber insulators in the salt fog test chamber under different conditions and levels of contamination. Then, the leakage current of the insulators was measured under different conditions and was used to predict the flashover voltage and flashover time based on a neural network. In [32], the effect of temperature and humidity on the flashover voltage of ceramic insulators contaminated with dust and moss was studied. Furthermore, in [33], the flashover voltage of pin-type porcelain insulators (11kV) was predicted based on several input variables, such as temperature, uniform surface pollution (with different pollution concentrations), and insulator inclination angles relative to the cross-arm. This research was carried out through experimental tests. Additionally, a statistical analysis was conducted to identify the significant variables affecting the flashover voltage.

Despite the research conducted, the comprehensive studies have yet to be presented regarding the effect of different pollution levels (natural and artificial) on the flashover voltage of insulators under various humidity with different temperatures. Notably, the simultaneous effects of changes in pollution severity, humidity levels, and temperature variations on the performance of ceramic insulators have yet to be widely evaluated and investigated. For this purpose, the current research investigates the simultaneous effect of humidity and temperature on the flashover voltage of insulators with different pollutions. The flashover voltage of five types of glass and porcelain insulators with different profiles has been measured. In these experimental tests, the samples are subjected to different levels of artificial pollution (light, medium, and heavy). Additionally, two other types of insulators have been examined with natural pollution. These insulators have been separated from overhead lines near a power plant. The samples of the mentioned insulators have also been experimented with at four relative humidities, 63, 73, 83, and 90%, and under different temperatures of 18°C, 25°C, and 32°C, and then their flashover voltages have been measured, and finally, the results have been analyzed. Then, a mathematical relationship has been proposed and analyzed to predict the flashover voltage of insulators under different pollutions, humidities, and temperatures, moreover, the correction factor relationship of the flashover voltage is also defined. By calculating the parameters of this relationship, flashover voltage is determined under various humidities versus relative humidity 63%.

2. SAMPLE OF INSULATORS, EXPERIMENTAL SETUP, AND TEST METHOD

2.1. Sample of insulators

In this research, five types of insulators with different profiles have been selected to measure flashover voltage under different levels of artificial and natural pollution and also under non-pollution conditions. In these experiments, the effects of humidity and temperature are also studied. Fig. 1 and Table 1 demonstrate the considered insulators' characteristics, respectively.

2.2. Experimental setup

Fig. 2 shows the laboratory setup and the schematic of the flashover voltage measurement system of insulators. The flashover voltage test of the studied insulators is performed in a fog chamber with dimensions of 2x2x2 meters (Fig. 2-(b)). The housing is wood, and a plastic cover is used for controlling temperature and

Table 1. Specifications of the studied insulators.

Insulator Type	Unit spacing (H, cm)	Shed diameter (D, cm)	Leakage distance (L, cm)	Total surface area (cm ²)	Insulators geometry
A(porcelain)	20	26	46	2100	
B(glass)	17.8	33	55	3750	
C(porcelain)	16.4	27.8	40.7	2377	
D, F(porcelain)	15	25	32	1660	
E, G(glass)	17	28	38	2212	



Fig. 1. View of the studied insulators: a Type A; b Type B; c Type C; d Type D; e Type E.

humidity. To produce and apply high voltage, three single-phase transformers, each able to produce AC voltage up to 100kV, 50Hz, with 5kVA power, have been used in a form of cascade connection. A current-limiting resistor (R) is used at the output of the transformer assembly. Also, the voltage applied to the insulators is measured using capacitor dividers (C). Fig. 2-(c) shows the transformer set with cascade connection and capacitor dividers. Also, to increase the humidity of the climate chamber, the required humidity is produced by a fog generator. For this purpose, the required humidity is provided using a fog generator so that, when the humidity reaches the desired level and stabilizes through a humidity controller, the amount of humidity is measured using a hygrometer. Also heaters are used to increase the temperature, and it is measured by a thermometer inside the chamber. Fig. 2-(b) shows the humidity generator and heaters.

2.3. Flashover voltage measurement

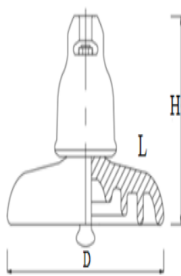
In flashover voltage measurement, the studied insulator samples are subjected to AC voltage and the increasing trend continues until the insulators experience electrical discharge. In critical conditions, when an electrical flashover occurs on the insulators, the measured voltage is read as flashover voltage. Accordingly, a voltage increase of 2kV/s is applied, and all tests are performed ten times. The results with a standard deviation of less than 10% are considered valid tests. flashover voltage and relative standard deviation (RSD) values are calculated using the following relationships [3].

$$U_f = \frac{[\sum_{i=1}^N U_i]}{N} \quad (1)$$

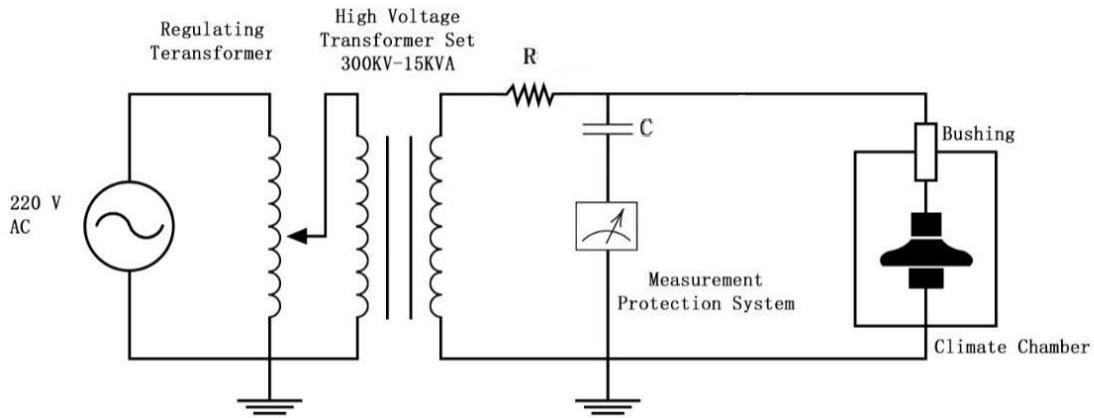

(a)



(b)



(c)



(d)

Fig. 2. a) Schematic of flashover voltage measurement system; b) Fogger and heaters; c) High voltage transformers and capacitor dividers; d) Climate chamber.

Table 2. Pollution level based on IEC 60815.

ESDD (mg/cm ²)	surface pollution
0.03 to 0.06	Light
0.06 to 0.1	medium
More than 0.1	heavy

2.4. Artificial pollution and determination of its severity level

There are different methods to create artificial pollution in the laboratory environment, which are stated in the IEC 60815 standard. According to this standard, artificial pollution includes two methods: salt fog and solid layer, which we have used from the solid layer in this paper. In the solid layer method, a solution with the appropriate amount of NaCl and 40 grams of kaolin with 1 liter of distilled water is prepared, and a pollution layer is created on the surface of the insulators. By using kaolin and different amounts of salt, different levels of pollution are obtained [34]. The IEC60815 standard prescribes using the ESDD to assess insulator surface pollution. ESDD is calculated based on the temperature of the dissolved pollution solution and its electrical conductivity in distilled water. It is mixed with 500ml of distilled water to dissolve the pollution on the surface of the contaminated insulator. An electrical conductivity meter and a thermometer were then used to measure the solution's temperature and electrical conductivity. When the pollution solution's initial electrical conductivity is known, Eq. (3) can be used to find the conductivity at 20°C [34].

$$RSD\% = \frac{1}{U_f} \sqrt{\frac{\sum_{i=1}^N (U_i - U_f)^2}{N - 1}} \times 100 \quad (2)$$

In these relationships, U_f is the flashover voltage of an insulator. U_i is the flashover voltage for each insulator test, N is the number of valid tests, and σ is the error of relative standard deviation.

$$\sigma_{20} = \sigma_{\theta} (1 - b(\theta - 20)) \quad (3)$$

Table 3 Electrical conductivity and ESDD amounts for the studied insulators at 20°C.

Insulator Type	Kaolin (gr)/salt(gr)	Conductivity (S/m)	ESDD (mg/cm ²)	Pollution severity
A	40/20	0.03535	0.0458	Light
B	40/20	0.0456	0.0334	Light
C	40/20	0.0287	0.0326	Light
D	40/20	0.0261	0.042	Light
E	40/20	0.0335	0.0412	Light
A	40/40	0.0531	0.0705	Medium
B	40/40	0.0987	0.074	Medium
C	40/40	0.0583	0.0678	Medium
D	40/40	0.0468	0.077	Medium
E	40/40	0.0512	0.0638	Medium
A	40/80	0.0731	0.101	Heavy
B	40/80	0.142	0.1076	Heavy
C	40/80	0.086	0.1013	Heavy
D	40/80	0.0661	0.1106	Heavy
E	40/80	0.093	0.118	Heavy
F	Natural Pollution	0.056	0.097	Medium
G	Natural pollution	0.0145	0.0178	Light

Where σ_θ is the measured electrical conductivity of the solution at the temperature θ in terms of s/m, σ_{20} is the electrical conductivity of the solution at a temperature of 20°C in terms of s/m, and b denotes the correlation of temperature θ , which is obtained from Eq. (4). As stated in Eq. (5), S_a soluble salinity at 20°C in terms of mg/cm³, finally, according to Eq. (6), ESDD is calculated in terms of mg/cm² [35].

$$b = 0.9 \times 10^{-5} \times \theta^2 - 0.8 \times 10^{-3} \times \theta + 0.0353 \quad (4)$$

$$S_a = (5.7 \times \sigma_{20})^{1.03} \quad (5)$$

$$ESDD = \frac{S_a \times v}{A} \quad (6)$$

Where S_a indicates the soluble salinity in mg/cm³, V is the pollution solution volume in cm³, and A is the cleaned surface of the insulator in cm². Then, according to the value of ESDD, the pollution severity of the insulator surface is determined according to Table 2 [30]. The results of conductivity and ESDD values of the insulators at a temperature of 20°C have been shown, as well as their pollution severity levels.

3. MEASUREMENT AND ANALYSIS OF THE FLASHOVER VOLTAGE OF INSULATORS

In order to analyze and evaluate the performance of the porcelain and glass insulators, flashover voltage tests on five types of insulators are examined in a clean state with different levels of artificial pollution. Also, two insulators with natural pollution are considered these tests are performed under different humidity levels (63%, 73%, 83%, and 90%) and temperatures (18, 25, and 32°C). flashover voltage measurement results have been expressed and analyzed in this section.

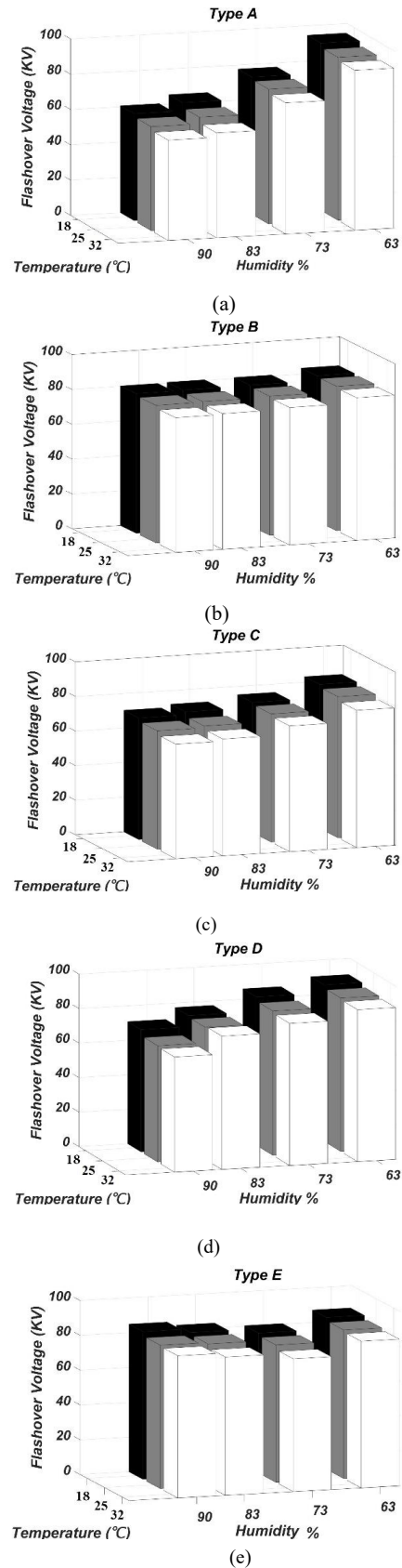

Fig. 3. Flashover voltage of the studied insulators under clean conditions and different levels of humidities and temperatures. a) Type A; b) Type B; c) Type C; d) Type D; e) Type E.

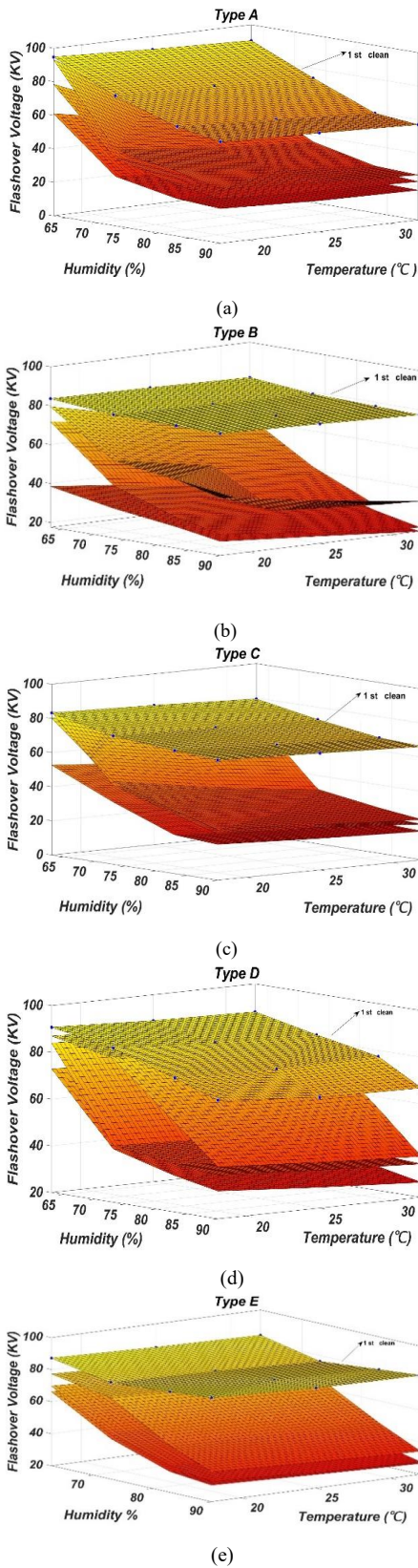

Fig. 4. Flashover voltage of the studied insulators under different pollution, humidities, and temperatures. a) Type A; b) Type B; c) Type C; d) Type D; e) Type E. (1 st: Clean; 2 st: Light pollution; 3 st: Medium pollution; 4 st: Heavy pollution).

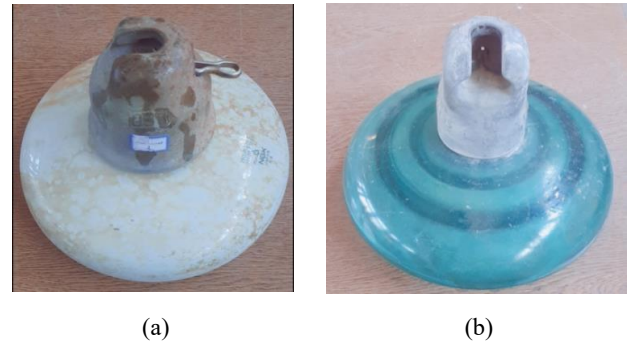

Fig. 5. The studied insulators with natural pollution. a) Type F; b) Type G.

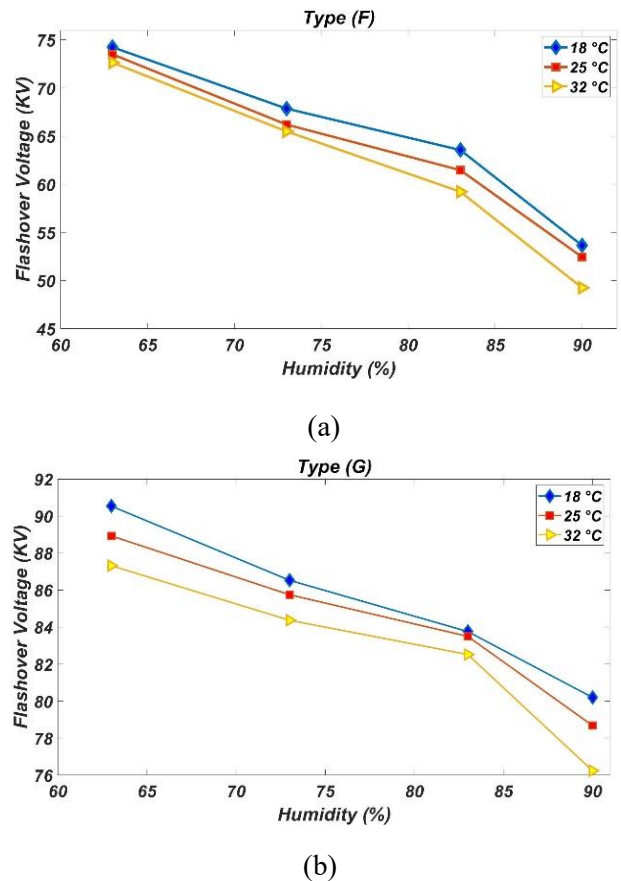

Fig. 6. Flashover voltage of insulators with natural pollution and under different humidities and temperatures. a) Type F; b) Type G.

3.1. The clean insulators under different humidities and temperatures

In this section, the studied insulators are considered under clean and dry conditions. Then, their flashover voltages are measured under various humidities and temperatures. Fig. 3 presents the results of the flashover voltage tests conducted on the studied insulators under clean conditions as well as different levels of humidity and temperature.

According to Fig. 3, the flashover voltage of the clean insulators has decreased with increasing temperature. In these experiments, the reduction of flashover voltage due to the increase in temperature in all five types of insulators was almost similar. With the increase in temperature from 18°C to 32°C, it decreased by about 4kV to 6kV on average. It can also be seen in Fig. 3 that with the simultaneous increase of humidity and temperature, the flashover

Table 4. Coefficients of relationship (7) for the studied insulators.

Type	Coefficients				R ²
	a	b	c	d	
A	1990636.346	-0.525516301	-0.477997996	-2.507691934	92.87%
B	288862.3858	-0.448321824	-0.570152451	-1.939045288	88.32%
C	21340481.24	-0.312237206	-0.5718748	-2.86124228	92.44%
D	482797.1244	-0.450718416	-0.170525483	-2.268361606	90.81%
E	542949.6125	-0.291026616	-0.157937597	-2.22890168	94.59%

Table 5. Comparison of the measured and estimated flashover voltage amounts.

Type	ESDD (mg/cm ²)	T (°C)	(%) H	V _{measure} (kV)	V _{estimate} (kV)	Error(%)
A	0.0458	18	83	38.83	38.9	-0.18
B	0.0334	18	83	52.83	48.5	8.19
C	0.0326	18	83	37.23	38.4	-3.14
D	0.0420	18	83	58.39	54.6	6.49
E	0.0412	18	83	49.39	45.9	7.06
A	0.0705	25	83	27.90	26.5	5.02
B	0.0740	25	83	28.64	28.1	1.88
C	0.0678	25	83	27.36	25.3	7.52
D	0.0770	25	83	37.42	39.3	-5.02
E	0.0638	25	83	35.43	38.4	-8.40
A	0.1010	18	90	20.70	21.2	-2.41
B	0.1076	18	90	24.90	24.5	1.61
C	0.1013	18	90	20.98	21.40	-2.01
D	0.1106	18	90	31.92	29.40	7.89
E	0.1180	18	90	30.38	28.20	7.17

voltage of the studied insulators has decreased significantly. For example, in type A insulators, due to the increase in humidity and temperature, flashover voltage has decreased from 94kV to 57kV.

Also, the effect of increasing humidity and temperature on the flashover voltage of type B insulators was the least. Meanwhile, in the porcelain insulators, the effect of increasing humidity and temperature on the reduction of flashover voltage was more striking compared to the glass insulators. The experimental findings proved that in clean conditions and with an increase in humidity, the flashover voltage of type E glass insulator behaved differently, so that with an increase in humidity, the flashover voltage value first decreased, and then with an increase in humidity from a specific value, the flashover voltage increased. This behavior can be due to various reasons, such as its geometric shape and structure so its performance in fog environments varies.

3.2. Artificial pollution under humidity and different temperatures

After the flashover voltage of the clean insulators, the insulator pollution flashover voltage tests are performed under three different pollution levels, light, medium, and heavy using the solid layer method and based on the IEC60815 standard. (according to results in Table 3). After creating artificial pollution on the samples of insulators, in order to analyze the effects of humidity and

Table 6. Constant values of C_r for the insulator samples.

temperature	pollution	Insulator A			Insulator B			Insulator C		
		P1	P2	q ₁	P1	P2	q ₁	P1	P2	q ₁
18	Light	0.2469	0.7183	1.629	0.4758	-20.53	-53.55	0.09197	4.812	-52.39
18	medium	0.1695	-3.589	-55.91	0.0936	1.298	2.394	0.1862	-3.507	-54.78
18	Heavy	0.2012	-7.215	-57.54	-1.495	261.4	104.6	-0.32	50.14	-33.13
25	Light	0.277	-5.544	-51.09	-0.2512	52.24	-26.48	0.05705	7.853	-51.55
25	medium	0.1096	9.477	-46.62	0.0802	7.04	-50.9	0.2773	-13.61	-59.14
25	Heavy	0.2168	-7.274	-56.61	-34.4	192.5	231.2	0.03846	11.61	-48.99
32	Light	0.2529	-4.534	-51.61	0.0441	17.6	-42.6	0.2516	-11.64	-58.78
32	medium	0.2472	-4.329	-51.76	0.0395	9.753	-50.75	0.2554	-12.91	-59.83
32	Heavy	0.2814	-12.04	-57.31	-25.93	123.7	155	0.2105	-6.423	-56.16

temperature	pollution	Insulator D			Insulator E		
		P1	P2	q ₁	P1	P2	q ₁
18	Light	-77.7	262.8	339.6	0.7678	-0.1311	-0.05781
18	medium	0.4164	-23.86	-60.63	0.0066	24.15	-39.28
18	Heavy	-0.2928	-11.2	-55.75	-0.1577	43.97	-29
25	Light	0.7589	-0.1065	-0.0226	0.7589	-0.1284	-0.05487
25	medium	0.3816	-21.18	-60.14	-0.1086	33.98	-35.86
25	Heavy	0.255	-8.869	-55.8	0.02596	17.05	-44.34
32	Light	-100.1	312.2	409.9	0.07549	-0.1268	-0.0524
32	medium	0.3569	-19.42	-59.94	-0.2775	50.2	-30.29
32	Heavy	0.6364	-51.64	-80.11	0.03816	14.7	-45.91

temperature on their flashover voltage tests, they are performed under different levels of humidity and temperature. Fig. 4 shows the results of the flashover voltage test of the insulators under different levels of artificial pollution and humidities (1 st: Clean / 2 st: Light pollution / 3 st: Medium pollution / 4 st: Heavy pollution).

The results in Fig. 4 demonstrate that the severity of pollution or the amount of ESDD increases, the electrical conductivity of the insulator surface rises, and leads to a higher leakage current passing through the surface, so that it causes surface electrical discharges. Notably, there is a direct relationship between humidity and these discharges. Additionally, an increase in ESDD, combined with higher humidity and temperature, has a more significant impact on reducing the flashover voltage. The experimental results showed that as ESDD increases, the flashover voltage of type B and E glass insulators decreases significantly. However, when ESDD, humidity, and temperature increase simultaneously, the most significant reduction in flashover voltage is observed in insulator types A and C.

Meanwhile, under clean conditions (without pollution) and at a humidity of 63% with a temperature of 18°C, the flashover voltage of insulator types A and C is 94kV and 83kV, respectively.

However, when pollution increases to a heavy level and the humidity rises to 90% with a temperature of 32°C, their flashover voltage drops to approximately 18kV and 17kV, respectively.

3.3. Natural pollution under different humidities and temperatures

In this section, the insulators type F and G (similar to types D and E) have been selected. They have been removed from the overhead line after several years of operation and have natural pollution. In order to evaluate the effect of humidity and temperature on the flashover voltage of these insulators, their flashover voltage is measured under different levels of humidity and temperature. Fig. 5 shows the studied insulators with natural pollution. According to the conducted tests, the results of the flashover voltage test of insulators with natural pollution under different levels of humidity and temperature are shown in Fig. 6.

The results show that the flashover voltage of the studied insulators under natural pollution has decreased with increasing temperature and humidity. An increase in humidity and temperature increases the electrical conductivity of the insulators surface and decreases their flashover voltage. Also, in both insulators, increasing the air temperature of the test chamber has a similar effect so that their flashover voltage decreases almost the same amount. The effect of humidity on the porcelain insulator is greater than that of the glass insulator (due to the difference in height and creepage distance). In the porcelain insulator, an increase in humidity causes a further decrease in flashover voltage.

In the next stage, after completing all the tests, the natural pollution accumulated on the studied insulators was collected, and their pollution severity was determined according to the IEC 60815 standard. As shown in Table 3, the measured electrical conductivity of insulator types F and G was 0.056 S/m and 0.0145 S/m, respectively. Therefore, based on these values, the insulator sample of type F falls under the medium pollution level, while type G insulators is classified under the light pollution level.

4. RELATIONSHIP BETWEEN THE FLASHOVER VOLTAGE OF THE STUDIED INSULATORS WITH POLLUTION, HUMIDITY, AND TEMPERATURE

In this section, in order to predict the flashover voltage of the studied insulators under different pollutions, humidities, and temperatures, a mathematical relationship is proposed. In Eq. (7), the dependence of flashover voltage on pollution, humidity, and temperature parameters is shown.

$$V_F = a ESDD^b \times T^c \times H^d \quad (7)$$

Where V_F ESDD, T , and H are flashover voltage equivalent salt deposit density, temperature, and humidity, respectively, and the values of a , b , c , and d are coefficients that are obtained according to the results of various tests on the studied insulator samples.

Curve fitting derived from the flashover voltage data of each insulator has been utilized to determine the coefficients of the mathematical Eq. (7). It is worth noting that various methods for curve fitting are available in MATLAB software. In this study, the polyfit command in MATLAB, which is used for function estimation, has been employed.

The coefficients of Eq. (7) are listed in Table 4. According to the obtained coefficients, it can be seen that there is a negative correlation between flashover voltage and factors affecting it, such as pollution, humidity, and temperature. This negative correlation indicates that the flashover voltage of the studied insulators continuously decreases with the increase in pollution severity, temperature, and also relative humidity.

It is worth mentioning that according to the obtained coefficients of the above relationship for the sample of insulators, the effect

of each parameter on flashover voltage is different from the other. Such parameters alone may not have a significant effect on the flashover voltage of the studied insulators. For example, it cannot be clearly stated that humidity has a more significant effect on flashover voltage than temperature. Because the flashover voltage of a type of insulator may not change significantly with an increase in temperature up to a certain level, or the flashover voltage of a type of insulator may not change much with an increase in humidity from one level to another.

However, under other relative levels of humidity, these effects are considerable. For example, with an increase in humidity from 63% to 73% and under a constant temperature, flashover voltage decreases by about 40kV.

However, with an increase in humidity from 73% to 83%, the value of flashover voltage decreases by about 10kV. It should be noted that the flashover voltage in constant humidity and the increase of temperature from 25°C to 32°C is not very high, and it will only decrease by about 4kV. But, with an increase in temperature from 18°C to 25°C, the flashover voltage will considerably decrease by about 30kV.

Tables 4 and 5 present the R^2 values and the error values between the estimated and measured flashover voltage of the studied insulator samples. Table 5 indicates that the error values are consistently less than 10%, while Table 4 shows that the maximum error in R^2 is 12%. These results demonstrate the high accuracy of the proposed relationship.

5. CORRECTION FACTOR OF FLASHOVER VOLTAGE AND RELATIVE HUMIDITY

According to the test results performed on different insulator samples, between the flashover voltage values of the insulators (U_F) under different humidity levels, a correlation (C_f) can be defined. This relationship is defined as follows.

$$C_f = \frac{U_{F'}}{U_F} \quad (8)$$

In the above relation, C_f is correction factor of flashover voltage, $U_{F'}$ indicates flashover voltage of insulator samples under different levels of humidity and U_F is flashover voltage of insulator samples under an environment relative humidity of 63%. To find the relationship between C_f and humidity, Eq. (9) has been defined based on the results of the experiments, using this relation, flashover voltage value can be obtained under different humidities.

$$C_f = \frac{P_1 H + P_2}{H + q_1} \quad (9)$$

In this regard, H is the humidity in the test process. P_1 , P_2 , and q_1 are constant values, and they are obtained by curve fitting in MATLAB software based on test results. The constant values are given in Table 6 under different pollution levels and temperatures.

Based on Table 6 and for different types of insulators, the estimated and real C_f are shown in Fig. 7. This figure shows that the test results agree well with the estimated curve of Eq. (9) for all the studied insulators. This can be used to design insulators under different humidities.

For example, for insulator type A, the flashover voltage value at 63% humidity and 18°C temperature is 78.43kV. Now, in order to predict the flashover voltage only under a relative humidity of 83%, it is sufficient to multiply the calculated C_f from Eq. (9) ($C_f = 0.3881$) by the above flashover voltage value; as a result, the flashover voltage value will be 30.44kV.

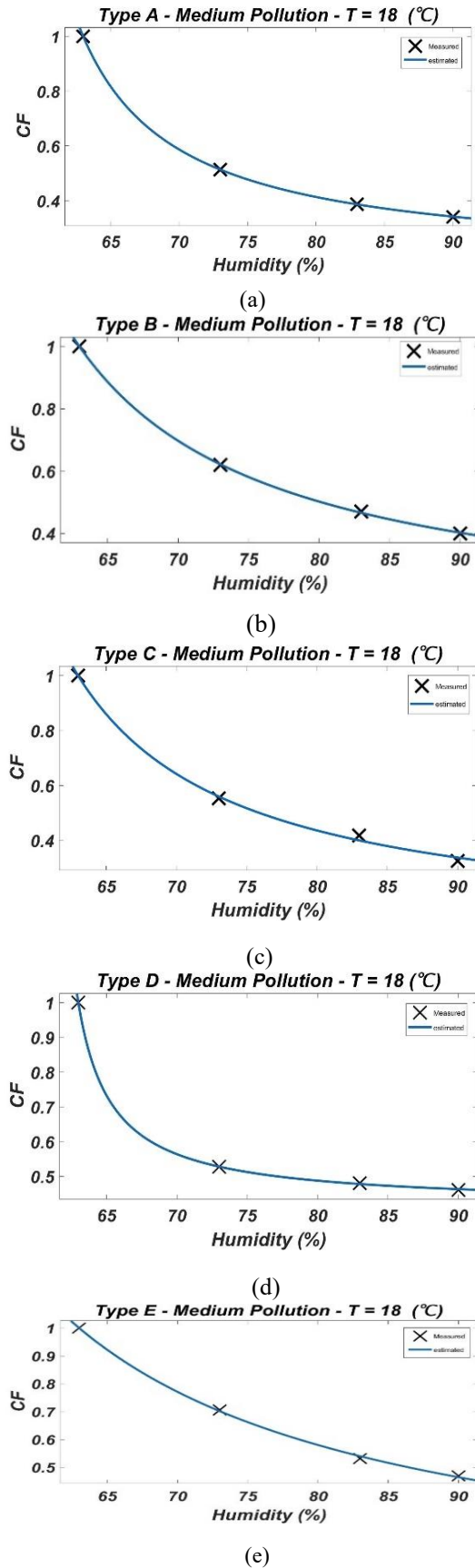

Fig. 7. A correction factor of the studied insulators under different temperatures and pollutions.

6. CONCLUSION

In this paper, the flashover voltage of porcelain and glass insulators is measured and analyzed under artificial/natural pollution conditions and different levels of humidity and temperature. According to experimental tests, the following results were obtained:

- The flashover voltage of the studied insulators decreases under different pollution levels with increasing humidity. Under artificial/natural pollution, the reduction of flashover voltage due to higher humidity in all insulators was greater than in the clean condition. It is worth mentioning that in the clean condition, with increasing humidity, the insulators suffer fewer electrical discharges.
- The increase in the pollution level does not have much effect on the reduction of the insulation strength of the insulators, but with the simultaneous increase in the levels of pollution, humidity, and temperature, the flashover voltage decreases significantly. In the worst case, for the type A insulator under light pollution at a temperature of 18 °C and humidity of 63%, the flashover voltage is around 94kV. However, when the conditions change to heavy pollution with humidity of 90% and temperature of 32 °C, the flashover voltage decreases to around 18kV, which shows a drop of about 82%.
- The flashover voltage of the studied insulators, under natural and artificial pollution, as well as clean conditions, decreases with increasing temperature. Notably, the flashover voltage of insulators is reduced due to the increase in temperature, and they follow the same trend under natural and artificial pollution and clean conditions. Compared to pollution and temperature, humidity has the greatest effect on the performance of insulators. The lowest effect of increased humidity was on the type B insulator, which can be attributed to the relatively high leakage distance.
- In order to predict and estimate flashover voltage under different values of pollution, humidity, and temperature, a mathematical relationship was proposed. This relationship can accurately predict the flashover voltage of the insulators. Such a model can be used to enhance accuracy in flashover risk assessment under environmental conditions, data-driven maintenance planning through weather-dependent performance curves, and optimized insulator selection for specific climatic and pollution zones.
- A correction factor for the flashover voltage of insulators under different humidities was also suggested relative to the environmental humidity of 63% (as a reference). This relationship shows that it is possible to estimate the flashover voltage of insulators under arbitrary humidity according to the defined correction factor.

Competing Interests

The authors declare that they have no competing interests.

Funding:

The authors did not receive support from any organization for the submitted work.

REFERENCES

- [1] E. M. Savadkoobi, M. Mirzaie, S. Seyyedbarzegar, M. Mohammadi, M. Khodsuz, M. G. Pashakolae, and M. B. Ghadikolaei, "Experimental investigation on composite insulators ac flashover performance with fan-shaped non-uniform pollution under electro-thermal stress," *Int. J. Electr. Power Energy Syst.*, vol. 121, p. 106142, 2020.
- [2] A. A. Salem, S. A. Al-Gailani, A. A. G. Amer, M. Alsharif, M. Bajaj, I. Zaitsev, R. Ngah, and S. S. Ghoneim, "Classification of rtv-coated porcelain insulator condition under different profiles and levels of pollution," *Sci. Rep.*, vol. 14, p. 22759, 2024.

- [3] M. Faramarzi Palangar and M. Mirzaie, "Designation of an indicator for flashover prediction of porcelain and glass insulators based on experimental tests," *J. Oper. Autom. Power Eng.*, vol. 3, no. 2, pp. 147–157, 2015.
- [4] A. A. Salem, R. Abd Rahman, and S. Al-Ameri, "Pollution flashover characteristics of high-voltage outdoor insulators: Analytical study," *Arab. J. Sci. Eng.*, vol. 47, pp. 2711–2729, 2022.
- [5] Y. Guo, X. Jiang, Y. Liu, Z. Meng, and Z. Li, "Ac flashover characteristics of insulators under haze-fog environment," *IET Gener. Transm. Distrib.*, vol. 10, no. 14, pp. 3563–3569, 2016.
- [6] B. Dony, Z. Zhang, N. Xing, and H. Yang, "Ac flashover voltage model for polluted suspension insulators and an experimental investigation in salt fog," *IEEE Access*, vol. 8, pp. 187411–187418, 2020.
- [7] A. A. Salem and R. Abd-Rahman, "Pollution flashover under different contamination profiles on high voltage insulator: Numerical and experiment investigation," *IEEE Access*, vol. 9, pp. 37800–37812, 2021.
- [8] Z. Yang, X. Jiang, X. Han, Z. Zhang, and J. Hu, "Influence of pollution chemical components on ac flashover performance of various types of insulators," *IET Gener. Transm. Distrib.*, vol. 4, no. 2, pp. 105–112, 2019.
- [9] M. Mirzaie and A. Azizi Tousi, "Impact of pollution location on time and frequency characteristics of leakage current of porcelain insulator string under different humidity and contamination severity," *J. Oper. Autom. Power Eng.*, vol. 1, no. 2, pp. 74–83, 2013.
- [10] K. Belhouchet, I. Ghadbane, A. Zemmit, L. Ouchen, and A. Zorig, "Measurement and evaluation of the flashover voltage on polluted cap and pin insulator: An experimental and theoretical study," *Electr. Power Syst. Res.*, vol. 236, p. 110979, 2024.
- [11] A. A. Salem, K. Y. Lau, Z. A. Al-Malek, S. A. Al-Gailani, and C. W. Tan, "Flashover voltage of porcelain insulator under various pollution distributions: Experiment and modeling," *Electr. Power Syst. Res.*, vol. 208, p. 107867, 2022.
- [12] L. Ouchen, A. Bayadi, and R. Boudiss, "Dynamic model to predict the characteristics of the electric arc around a polluted insulator," *IET Gener. Transm. Distrib.*, vol. 14, no. 1, pp. 83–90, 2020.
- [13] A. A. Salem, R. Abd-Rahman, M. Kamarudin, H. Ahmad, N. Jamail, N. Othman, M. Ishak, M. Baharom, and S. Al-Ameri, "Proposal of a dynamic numerical approach in predicting flashover critical voltage," *J. Electr. Eng.*, vol. 10, no. 1, pp. 51–58, 2019.
- [14] M. Ghayedi, R. Shariatinasab, and M. Mirzaie, "Ac flashover dynamic model suggestion and insulation level selection under fan-shaped pollution," *Int. J. Electr. Power Energy Syst.*, vol. 134, p. 107438, 2022.
- [15] Y. Hu, X. Jiang, S. Guo, and Z. Yang, "Comparison of ac flashover performance of snow-accreted insulators under natural and artificial simulation environments," *IEEE Access*, vol. 8, pp. 115559–115567, 2020.
- [16] Y. Hu, X. Jiang, S. Guo, R. Xian, C. Zong, Z. Yang, and X. Han, "Influence of snow accretion on arc flashover gradient for various types of insulators," *IET Gener. Transm. Distrib.*, vol. 14, no. 12, pp. 2361–2367, 2020.
- [17] M. Farzaneh, *Atmospheric Icing of Power Networks*. Dordrecht: Springer, 2008.
- [18] L. Cui and M. Ramesh, "Prediction of flashover voltage using electric field measurement on clean and polluted insulators," *Int. J. Electr. Power Energy Syst.*, vol. 116, p. 105543, 2020.
- [19] L. Shu, Y. Liu, and X. Jiang, "Three-dimensional electric field simulation and flashover path analysis of ice-covered suspension insulator," *IET Gener. Transm. Distrib.*, vol. 5, no. 3, pp. 327–333, 2020.
- [20] X. Jiang, X. Han, Y. Hu, and Z. Yang, "Model for ice wet growth on composite insulator and its experimental validation," *IET Gener. Transm. Distrib.*, vol. 12, no. 3, pp. 556–563, 2018.
- [21] X. Han, X. Jiang, Z. Yang, and C. Bi, "A predictive model for dry-growth icing on composite insulators under natural conditions," *Energies*, vol. 11, no. 6, p. 1339, 2018.
- [22] A. A. Salem, R. Abd-Rahman, S. A. Al-Gailani, M. S. Kamarudin, and N. A. Othman, "Artificial intelligence techniques for predicting the flashover voltage on polluted cup-pin insulators," in *Advances in Intelligent Systems and Computing*, pp. 362–372, Springer, 2019.
- [23] X. Jiang, Y. Hu, L. Shu, Z. Zhang, J. Hu, Q. Hu, and Q. Wang, "Crystallisation effect of conductive ions in freezing water during phase transition and its effect on ice flashover voltage," *IET Gener. Transm. Distrib.*, vol. 10, no. 9, pp. 2147–2154, 2016.
- [24] L. Yang, X. Jiang, Y. Hao, L. Li, H. Li, R. Li, and B. Luo, "Recognition of natural ice types on in-service glass insulators based on texture feature descriptor," *IEEE Trans. Dielectr. Electr. Insul.*, vol. 24, no. 1, pp. 535–542, 2017.
- [25] X. Jiang, C. Fan, and Y. Xie, "New method of preventing ice disaster in power grid using expanded conductors in heavy icing area," *IET Gener. Transm. Distrib.*, vol. 13, no. 4, pp. 536–542, 2019.
- [26] Y. Bourek, N. M'Ziou, and H. Benguesmia, "Prediction of flashover voltage of high-voltage polluted insulator using artificial intelligence," *Trans. Electr. Electron. Mater.*, vol. 19, no. 1, pp. 59–68, 2018.
- [27] J. Sun, K. Hu, Y. Fan, J. Liu, S. Yang, X. Guo, and K. Zhang, "Flashover voltage and external insulation design for emus' insulators at high altitude with non-uniform distributed pollution," *IET Gener. Transm. Distrib.*, vol. 17, no. 14, pp. 3255–3265, 2023.
- [28] M. Chen, H. Yang, Z. Song, F. Zhou, and W. Shen, "Development path prediction of local arc over the wet contaminated insulator surface based on random walk theory," *Electr. Power Syst. Res.*, vol. 241, p. 111353, 2025.
- [29] Z. Zhang and X. Qiao, "Comparison of surface pollution flashover characteristics of rtv (room temperature vulcanizing) coated insulators under different coating damage modes," *IEEE Access*, vol. 7, pp. 40904–40912, 2019.
- [30] I. Ahmadi-Joneidi, A. A. Shayegani-Akmal, and H. Mohseni, "Leakage current analysis of polymeric insulators under uniform and non-uniform pollution conditions," *IET Gener. Transm. Distrib.*, vol. 11, no. 11, pp. 2947–2957, 2017.
- [31] M. M. Mohsenzadeh, S. Hasanzadeh, H. R. Sezavar, and M. H. Samimi, "Flashover voltage and time prediction of polluted silicone rubber insulator based on artificial neural networks," *Electr. Power Syst. Res.*, vol. 221, p. 109456, 2023.
- [32] S. Amalia, H. Azhar, B. Hidayatullah, A. Rajab, N. Novizon, Y. Warmi, and A. F. Kasmar, "The effect of humidity and temperature on flashover in high voltage transmission line ceramic insulators," *TEM J.*, vol. 13, no. 1, pp. 670–680, 2024.
- [33] R. N. Ghaly, S. S. Ghoneim, A. Ibrahim, W. Ziomek, P. Paramasivam, and H. Awad, "Performance of insulators under variation of pollution, inclined angle, and temperature based on the design of experiment," *Res. Eng.*, vol. 24, p. 103148, 2024.
- [34] M. Faramarzi, M. Mirzaie, and A. Mahmoudi, "Improved flashover mathematical model of polluted insulators: A dynamic analysis of the electric arc parameters," *Electr. Power Syst. Res.*, vol. 179, p. 106083, 2020.
- [35] International Electrotechnical Commission (IEC), *Artificial pollution tests on high voltage insulators to be used on A.C. systems (IEC 60815:1991)*. Geneva: IEC, 1991.